

TM 11-5511

TO 16-35 TS 505-5
DEPARTMENT OF THE ARMY TECHNICAL MANUAL

ELECTRONIC MULTIMETER TS-505/U

This copy is a reprint which includes current pages from Changes 1 through 5.

Changes in, force:C1,C3,C4, and C5

TM 11-5511
C5

ELECTRONIC MULTIMETER TS-50S/U

CHANCE }
No. 5 }

HEADQUARTERS
DEPARTMENT OF THE ARMY
WASHINGTON, D. C., 11 May 1964

TM 11-5511, 8 June 1951, is changed as follows:

Page 7, paragraph 7. Delete the information for "Accuracy" indication and substitute: ± 4 percent of full scale on dc voltage; ± 6 percent of full .scale from 30 cps to 500 kc for sinusoidal input; all voltage reading from 500 kc to 500 mc are rough indications only, without accuracy requirements; ± 4 percent of ohmmeter arc length on ohms scale

Page 15, paragraph 18b. Add the following to the Note: Readings obtained on signals above 500 kc are approximate and should be used only as a relative voltage indication.

By Order of the Secretary of the Army

EARLE G; WHEELER,
General, United States Army,
Chief of Staff

Official:

J. C. LAMBERT,
Major General, United States Army,
The Adjutant General.

Distribution:

Active Army:

USASA (2)
CNGB (1)
C/COMMEL (7)
CofT (1)
CofEngrs (1)
TSG (1)
CofSptS (1)
USAARMBD (2)
USA Trans Bd (2)
USAARTYBD (2)
USARADBD (2)
USAAVNBD (2)
USAAESWBD (2)
USCONARC (6)
USAMC (5)
USAECOM (7)
USAMICOM (14)
USASMCOM (2)
ARADCOM (2)
ARADCOM Rgn (2)
OS Maj Comd (3) except
USARYIS (5)
OS Base Comd (2)
LOGCOMD (2)
Armies (2)
Corps (2)
USA Corps (3)
11th Air Assault Div (3)
USASA 318th Bn (5)
319th USASA Bn (5)
320th USASA Bn (5)
321st USASA Bn (5)
507th USASA Gp (5)
508th USASA Gp (5)
177th USASA Co (5)
182d USASA Co (5)
183rd USASA Co (5)
184th USASA Co (5)
226th USASA Co (5)
600th USASA Co (5)
251st USASA Co (5)

252d USASA Co (5)
102d USASA Det (5)
104th USASA Det (5)
Instl (2) except Ft Gordon
(5), Ft Hancock (4), Ft
Huachuca (35). Ft Mon-
mouth (731)
USAWC (2)
USCGSC (20)
Br Svc (2) except USASCS
(325), USACMLCSCH
(20). USAES (20),
USAAMS (40), USAIS
(20), MFSS (20). PMGS
(20), USAADS (01)
USASESCS (150)
USA Cbt Survl Sch 1(30)
USASA Sch (100)
USAOGMS (100)
USASCC (4)
USAECDA (2)
USACBRCA (1)
USACECDA (1)
USACECDA (Monmouth
Ofc) (1)
USAMSCDA (1)
USAOCDA (2)
USAQMCDA (1)
USATCDA (2)
USAADCDA (2)
USAARMCDA (2)
USAAVNCDA (2)
USAARTYCDA (2)
USASWCDA (2)
USA Elect Mat Agcy ('J9)
USARSOUTHCOM Sig Agcy
(1)
USATC AD (3)
USATC Armor (3)
USATC Engr (3)
USATC Inf (3)

AGO R951R-May

WRAMC (1)	USASA 14th Fld Sta (5)
Army Pic Cen (2)	USAERDL (5)
USA Mbl Equip Cen 41)	USA Cold Rgn RE Lab (2)
IJSAPRDC t5)	Natick Lab (5)
BAMC (5)	Madigna Gen Hosp (5)
USAINTC (51	MAAG: Iran, Taiwan (5)
MDW (1)	USARMIS, Paraguay (5)
Chicago Proc Dist (I)	JUSMMAT (6)
AMS (1)	USMTMSA (5)
Army Dep (2) except Sharpe	Def Lang Institute (20)
(3), Lexington, Tobyhanna	ARMISH (5)
(12), Sacramento (28), Ft	KMAG (5)
Worth (8), Letterkenny,	JUSMAG Thailand (5)
Savanna (5), Navajo (5),	USA CmlC Biological Lab (5\$)
Charleston (3), Anniston,	USASCC Det #2 (5)
Erie (8), Pueblo, Sierra	USASCC Det #3 (5)
(8), Atlanta, Columbus (8)	USASCC Det #4 (5)
Utah (8)	USASCC Det #6 (5)
GENDEP (OS) (2)	U\$ASCC Det #6 (5)
Sig Sec, GENDEP (OS) (5)	USASCC Det #7 (5)
Sig Dep (OS) (12)	USASCC Det #8 (5)
Army Tml (1) except	Unite org under fol TOE: (2
Oakland (5)	copies each except a indi-
POE (1)	cated)
Sig Fld Maint Shops (3)	1-7
WSMR (6)	1-17
USAELRDA (White Sands)	1-37
(13)	1-65
USATTCARC (1)	146
USATTCA (1)	1-67
USATTG (1)	1-75
USATTCP (1)	1-76
CSTATC (5)	1-107
Dugway PG (10)	1-127
Aberdeen PG (5)	1-137
Jefferson PG (6)	5-15
USAMOAMA (1)	5-16
Abn Sys Test Actv (5)	5-48
USASATSA (5)	5-278
Edgewood Arsenal 110)	5-500 (AA-AD)
Detroit Arsenal (5)	5-00
Rock Island Arsenal (5)	5-606
Redstone Arsenal (6)	6-100
US Army Test Cen (2)	6-101
1st CM Bde (5)	6-155
USASA, Taiwan (5)	6-156
USASA 75th Unit (5)	6-185
USASA 77th Unit (5)	6-186
USASA 2d Fld Sta (6)	6-200
USASA 4th Fld Sta (S)	6-201
USASA 9th Fld Sta (5)	6-215
USASA 12th Fld Sta (5)	6-216
USASA 13th Fld Sta (5)	6-295

6-296	17
6-300	17-51
6-301	17-100
6-302	29-1
6-315	29-15
6-316	29-16
6-346	29-25
6-346	29-28
6-386	29-35
6-585	29-36
6-615	29-51
6-616	29-56
7	29-57
7-52	29-65
7-100	29-76
9-217	29-76
9-510	29-79
11-5	29-105
11-6	29-109
11-7	30-25
11-8	30-26
11-16	32-52
11-35	32-57
11-36	32-67
11-38	32-68
11-55	32-78
11-56	32-500
11-57	33-56
11-85	33-500 (AA-AC)
11-86	33-600 (AA-AC)
11-87	37
11-97	39-51
11-98	39-52
11-116	44-7
11-117	44-112
11-155	44-445
11-157	44-446
11-158	44-447
11-215	44-448
11-216	44-544
11-500 (AA-AE) (4)	44-545
11-557	44-546
11-558	44-547
11-587	44-54
11-592	44-548
11-597	55-157
11-608	57
	57-100

NG: State AG (3); units-same as Active Army except allowance is one copy to each unit.

USAR: None.

For explanation of abbreviations used, see AR 320-50.

U.S. GOVERNMENT PRINTING OFFICE, 1994-700595

898-293

AGO 8961B

TECHNICAL MANUAL

ELECTRONIC MULTIMETER TS-505/U

TM 11-5511
Changes No. 4



HEADQUARTERS,
DEPARTMENT OF THE ARMY
Washington, D.C., 19 September 1963

TM 11-5511, 8 June 1951, is changed as follows:

Page 1. Delete paragraph 2 and substitute:

2. Index of Publications

Refer to the latest issue of DA Pam 310-4 to determine whether there are new editions, changes, or additional publications pertaining to this equipment. DA Pam 3104 is an index of current technical manuals, technical bulletins, supply bulletins, lubrication orders, and modification work orders that are available through publications supply channels. The index lists the individual parts (-10, -20, 35P, etc.) and the latest Changes to and revisions of each equipment publication.

Add paragraph 2.1 below paragraph 2.

2.1 Forms and Records

a. *Reports of Maintenance and Unsatisfactory Equipment.* Use equipment forms and records in accordance with instructions in TM 38-750.

b. *Report of Damaged or Improper Shipment.* Fill out and forward DD Form 6 (Report of Damaged or Improper Shipment) as prescribed in AR 700-58 (Army), NAVSANDA Publication 378 (Navy), and AFR 714 (Air Force).

c. *Reporting of Equipment Manual Improvements.* The direct reporting by the individual user of errors, omissions, and recommendations for improving this manual is authorized and encouraged. DA Form 2028 (Recommended Changes to DA Technical Manual Parts Lists or Supply Manual 7, 8, or 9) will be used for reporting these improvements. This form will be completed in triplicate using pencil, pen, or typewriter. The original and one copy will be forwarded direct to: Commanding Officer, U. S. Army Electronics Materiel Support Agency, ATTN: SELMS-MP, Fort Monmouth, NJ. One information copy will be furnished to the individual's immediate supervisor (e.g., officer, noncommissioned officer, supervisor, etc.).

TAGO 0000-B

Delete chapter 3 and substitute:

CHAPTER 3

MAINTENANCE INSTRUCTIONS

25. Scope of Maintenance

The maintenance duties assigned to the operator and organizational repairman of Electronic Multimeter TS-505/U are listed below together with a reference to the paragraphs covering the specific maintenance function. The duties assigned do not require tools or test equipment other than those issued with the multimeter.

- a. Daily preventive maintenance checks and services (par. 28).
- b. Weekly preventive maintenance checks and services (par. 29).
- c. Cleaning (par. 30).
- d. Monthly preventive maintenance checks and services (par. 31.1).
- e. Touch-up painting (par. 31.2).

26. Preventive Maintenance

Preventive maintenance is the systematic care, servicing, and inspection of equipment to prevent the occurrence of trouble, to reduce downtime, and to assure that the equipment is serviceable.

a. *Systematic Care.* The procedures given in paragraphs 28 through 31.1 cover routine systematic care and cleaning essential to proper up keep and operation of the equipment.

b. *Preventive Maintenance Checks and Services.* The preventive maintenance checks and services charts (pars. 28, 29, and 31.1) outline functions to be performed at specific intervals. These checks and services are to maintain Army electronic equipment in a combat serviceable condition; that is, in good general (physical) condition and in good operating condition. To assist operators in maintaining combat serviceability, the charts indicate what to check, how to check, and what the normal conditions are. The *references* column lists the illustrations, paragraphs, or manuals that contain detailed repair or replacement procedures. If the defect cannot be remedied by the operator, higher echelon, maintenance or repair is required. Records and reports of these check, and services must be made in accordance with the requirements set forth in TM 38-750.

27. Preventive Maintenance Checks and Services Periods

Preventive maintenance checks and services on Electronic Multimeter TS505/U are required daily, weekly, and monthly. Paragraphs 28, 29, and 31.1 specify the items to be checked and serviced. In addition to the

TAGO 6038-B

routine daily, weekly, and monthly checks and services, the equipment should be rechecked and serviced immediately before going on a mission and as soon after completion of the mission as possible.

28. Daily Preventive Maintenance Checks and Services Chart

Sequence No.	Item	Procedure	References
1	Completeness ..	Be sure the equipment is complete.	TM 11 -6625-239-12 (app. III). Par. 30.
2	Cleaning.....	Remove dirt anti moisture from exposed surfaces of the case and housing.	
3	Meter window	Inspect the meter window for broken glass.	
4	Pilot light.....	During operation (item 7 below), inspect for a burned-out pilot light.	
5	Meter movement.	During operation (item 7 below), check for sticking meter movement.	
6	Knobs and switches.	While making the operating check (item 7 below), observe that the mechanical action of each knob and switch is smooth and free of external or internal binding.	
7	Operation.....	Operate the equipment in accordance with paragraph 22. During operation, be alert for any unusual performance or condition.	

29. Weekly Preventive Maintenance Checks and Services Chart

Sequence No.	Item	Procedure	References
1	Cords and cables.	Inspect cords and cables for cuts, cracks, strain, fraying, or deterioration.	
2	Handles and latches.	Hand-check for looseness of handle and latches.	
3	Batteries.....	Inspect dry batteries for loose terminals and leakage.	
4	Preservation...	Inspect exposed metal surfaces for rust and corrosion. If present, refer to higher echelon for repair.	

30. Cleaning

Inspect the exterior of the multimeter. The exterior surfaces should be clean and free of dust, dirt, grease, and fungus.

- a. Remove dust and loose dirt with a clean soft cloth.

Warning: Cleaning compound is flammable and its fumes are toxic. Provide adequate ventilation. Do not use near a flame.

- b. Remove grease, fungus, and ground-in dirt from the cases; use a cloth dampened (not wet) with Cleaning Compound (Federal stock No. 7930-395-9542).

- c. Remove dust or dirt from plugs and jacks with a brush.

Caution: Do not press on the meter face (glass) when cleaning; the meter may be damaged.

- d. Clean the front panels, meters, and control knobs; use a soft clean cloth. If dirt is difficult to remove, dampen the cloth with water; mild soap may be used.

31. Monthly Maintenance

Perform the maintenance functions indicated in the monthly preventive maintenance checks and services chart (par. 31.1) once each month. A month is defined as approximately 30 calendar days of 8-hour-per day operation. If the equipment is operated 16 hours a day, the monthly preventive maintenance checks and services should be performed at 15-day intervals. Adjustment of the maintenance interval must be made to compensate for any unusual operating conditions. Equipment maintained in a standby (ready for immediate operation) condition must have monthly preventive maintenance checks and services performed on it. Equipment in limited storage (requires service before operation) does not require monthly preventive maintenance.

31.1. Monthly Preventive Maintenance Checks and Services Chart

Sequence No.	Item	Procedure	References
1	Completeness..	Be sure the equipment is complete.	TM 11-6625-239-12 (app. III). Par. 30.
2	Cleanliness....	Remove dirt and moisture from exposed surfaces of the case and housing.	
3	Cords and cables.	Inspect the cords and cables for cuts, cracks, strain, fraying or deterioration.	
4	Handle and latches.	Hand-check the handle and latches for looseness.	
5	Batteries	Inspect dry batteries for leakage..	

Sequence No.	Item	Procedure	References
6	Pluckout items	Inspect seating of readily accessible items of a pluckout nature such as fuses, connectors, tubes, and lamps. Do not remove, rock, or twist to inspect. Use only direct pressure to insure item is fully seated.	
7	Resistors and capacitors.	Inspect resistors and capacitors for cracks, blistering, or other detrimental defects.	
8	Preservation ...	Check all surfaces for evidence of fungus. Remove rust and corrosion, and spot-paint bare spots.	Par. 312
9	Publications ...	See that all publications are complete, serviceable, and current.	DA Pam 310-4.
10	Modifications ..	Check DA Pam 310-4 to determine if new applicable MWO's have been published. All URGENT MWO's must be applied immediately. All NORMAL, MWO's must be scheduled.	
11	Pilot light	During operation (item 14 below), inspect for burned-out pilot light.	
12	Knobs and switches.	While making the operating checks (item 14 below), observe that the mechanical action of each knob, dial, and switch is smooth and free of external or internal binding.	
13	Meter movement.	During operation (item 14 below), check for sticking meter movement.	
14	Operation	Operate the equipment in accordance with paragraph 22. During operation, be alert for any unusual performance or condition.	Par. 22.

31.2. Touchup Painting Instructions

Clean rust and corrosion from metal surfaces by lightly sanding them with fine sandpaper. Brush two thin coats of paint on the bare metal to protect it from further corrosion. Refer to the applicable cleaning and refinishing practices specified in TM 9-213.

Page 65. Delete appendix I and substitute:

APPENDIX

REFERENCES

Following is a list of references available to the operator and repairman of the multimeter.

DA Pam 310-4	Index of Technical Manuals, Technical Bulletins, Supply Bulletins, Lubrication Orders, and Modification Work Orders.
TM 9-213	Painting Instructions for Field Use.
TM 11-5527	Multimeters TS-352/U, TS352A/U, and TS-352B/U.
TM 11-6625-239-12	Operator's Organizational Maintenance Manual: Electronic Multimeters TS505A/U and TS-505B/U, and Multimeters TS-505C/U, and TS-505D/U.
TM 11-6625-239-20P	Organizational Maintenance Repair Parts and Special Tools List for Electronic Multimeters TS-505/U, TS-505A/U, and TS-505B/U, and Multimeters TS-505C/IJ, and TS-505D/U.
TM 11-62239-35P	Field and Depot Maintenance Repair Parts and Special Tools List: Electronic Multimeters TS-505/U, TS- A/U, TS-B/U, TS505C/U, and TS-505D/U.
TM 38-750	The Army Equipment Record System and Procedures.

By Order of the Secretary of the Army:

EARLE G. WHEELER,
General, United State Army,
Chief of Staff.

Official:

J. C. LAMBERT,
Major General, United States Army,
The Adjutant General.

Distribution:

Active Army:

DASA (6)	Tobybanna (12)
USASA (2)	Granite City (5)
CNGB (1)	USA Elct RD Actv, White Sands (13)
CofEngrs (1)	USA Elct RD Actv, Ft Huachuca (2)
TSG (1)	USA Trans Tml Comd (1)
CSigO (7)	Army Tml (1)
CofT (1)	POE (1)
CofSpt8 (1)	USAOSA (1)
USA CD Agcy (1)	AMS (1)
USCONARC (5)	WRAMC (1)
USAMC (5)	AFIP (1)
ARADCOM (2)	Army Pic Cen (2)
ARADCOM Rgn (2)	USA Mbl Spt Cen (1)
OS Maj Comd (3)	USA Elct Mat Agcy (12)
OS Base Comd (2)	Chicago Proc Dist (1)
LOGCOMD (2)	USARCARIB Sig Agcy (1)
USAECOM (5)	Sig Fld Maint Shop (3)
USAMICOM (4)	USAIS (5)
USASCC (4)	APG (5)
MDW (1)	Jefferson PG (5)
Armies (2)	Dugway PG (10)
Corps (2)	USAWECOM (5)
1st GM Bde (5)	CSTATC (5)
USATC AD (2)	USA QM R&E Comd (5)
USATC Engr (2)	CRREL (5)
USATC Inf (2)	USAPRDC (5)
USATC Armor (2)	USA CBR Lab (5)
USASTC (5)	USAERDL (5)
Instl (2) except Ft Belvoir (5)	USA Elct RD Lab (5)
Ft Monmouth (65)	Edgewood Arsenal (5)
Svc Colleges (2)	Raritan Arsenal (5)
Br Svc Sch (2) except	Rock Island Arsenal (5)
USASCS (325)	USAINTCA (5)
GENDEP (08) (2)	USAMOAMA (5)
Sig Dep (OL) (12)	USASATSA (5)
Sig Sec, GENDEP (5)	MGH (5)
Army Dep (2) except	LGH (S)
Ft Worth (8)	BAMC (5)
Lexington (12)	
Sacramento (28)	

TAGO 6038-B

USA Corps (3)	9-227
USARMIS (Paraguay) (5)	9-377
Units org under fol TOE:	9-500 (AA-AC)
(2 copies)	9-510
1-7	11-5
1-17	11-6
1-37	11-7
1-55	11-8
1-56	11-16
1-67	11-35
1-75	11-36
1-76	11-38
1-107	11-55
1-127	11-56
1-137	11-47
5-15	11-58
5-16	11-85
5-45	11-86
5-46	11-87
5-48	11-96
5-278	11-97
5-500 (AA-AD)	11-98
5-600	11-11
5-605	11-117
6-100	11-155
6101	11-157
6-155	11-215
6-156	11-216
6-185	11-500 (AA-AE, RM-RU)
6-186	11-555
9-200	11-557
6-201	11-58
6-215	11S87
6-216	11-5
6-285	11-597
6-286	11-608
6-300	17
6-301	17-51
6-302	117-100
6-315	29-1
6-316	29-15
6-345	29-16
6-346	29-21
6-385	29-25
6-386	29-26
6-386	29-35
6-615	29-36
6-619	29-51
7	29-55
7-52	29-5
7-100	29-57
9-47	29-65
9-87	29-75
9-217	29-76

29-99	44-102
29-105	44-112
29-109	44-435
30-25	44-436
39-26	44-437
32-51	44-445
32-52	44-446
32-56	44-447
32-57	44-448
32-67	44-535
32-68	44-536
32-77	44-537
32-78	44-544
32-500	44-545
33-56	44-546
33-500 (AA-AC)	44-547
33-600 (AA-AC)	44-548
37	55-157
37-100	57
39-51	57-100
39-52	

NG: State AG (3); units-same as Active Army except allowance is one copy each.

USAR: None.

For explanation of abbreviations used, see AR 320-50.

DEPARTMENT OF THE ARMY TECHNICAL MANUAL
DEPARTMENT OF THE AIR FORCE TECHNICAL ORDER
ELECTRONIC MULTIMETER TS-505/U

TM 11-5511
TO 33A1-12-55-1
CHANGES No. 3

DEPARTMENTS OF THE ARMY
AND THE AIR FORCE
WASHINGTON 25, D.C., 28 July 1960

TM 11-5511/TO 33A1-125-1, 8 June 1951, is changed as follows:

Note. The parenthetical reference to previous changes (example: ("page 10 of C 1")) indicates that pertinent material was published in the changes.

Page 16, paragraph 18a. Make the following changes:

Heading. Add the following warning notice below the heading:

Warning: If line voltage measurements are to be made, a potential hazard will exist unless the multimeter case is grounded to an external ground.

Subparagraph a(1). Add the following note after the subparagraph:

Note. Erratic meter indications may occur when the multimeter is set to the low ac voltage range. Ground the case of the multimeter to an external ground to eliminate this problem.

Page 16, paragraph 19. Add subparagraph d after subparagraph a:

d. Limitations and Qualification of Resistance Readings.

- (1) Misinterpretation of resistance readings obtained with Electronic Multimeter TS-505/U can result in unnecessary repairs to equipment, because resistors are mistakenly reported faulty.
- (2) The tolerance prescribed for the TS-505/U is ± 4 percent of arc length. The ± 4 percent of arc length does not result in a ± 4 percent resistance value reading. The possible indicated resistance of any resistor can be determined by using a computing device similar to that shown in figure 4.1. Figure 4.1 shows that a resistor rated at exactly 30 ohms could produce a reading on the TS-505/U between 25.5 and 35.5 ohms, with only 4 percent meter tolerance. If the resistor has a tolerance of ± 10 percent, the meter reading obtained will be between 22.7 and 38.1 ohms as shown in figure 4.2.

*These changes supersede C 2, 27 October 1958.

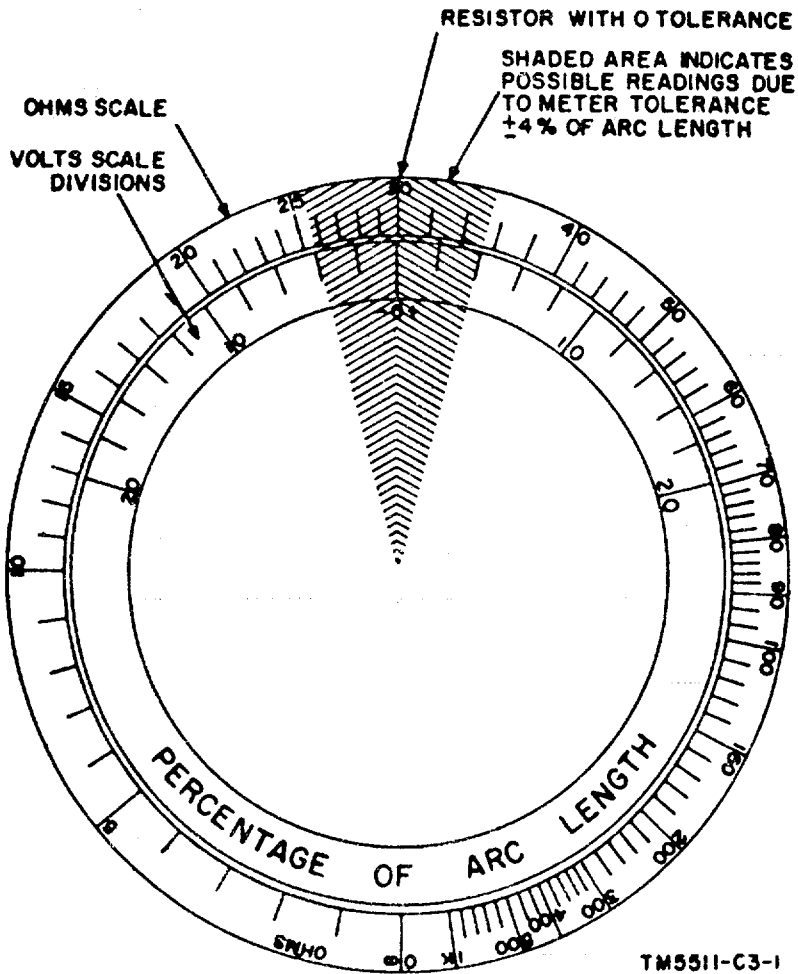

Figure 4.1. (Added) Computing device, indicating meter tolerance.

(3) A computing device similar to the one illustrated in figure 4.8 and calibrated as shown can be constructed of cardboard. The center scale can then be made to rotate and the device used as an aid for determining the limits between which a resistor tested with Electronic Multimeter TS-505/U is acceptable. The following examples show the step-by-step procedure for using the computing device

Examples:

1. Calculation for ± 0 -percent resistor.
 - a. Place ± 0 line at 30 on the ohms scale.
 - b. Read the ohms value, two divisions above and below ± 0 .
 - c. These readings are 25.5 ohms and 35.5 ohms (fig. 4.1).

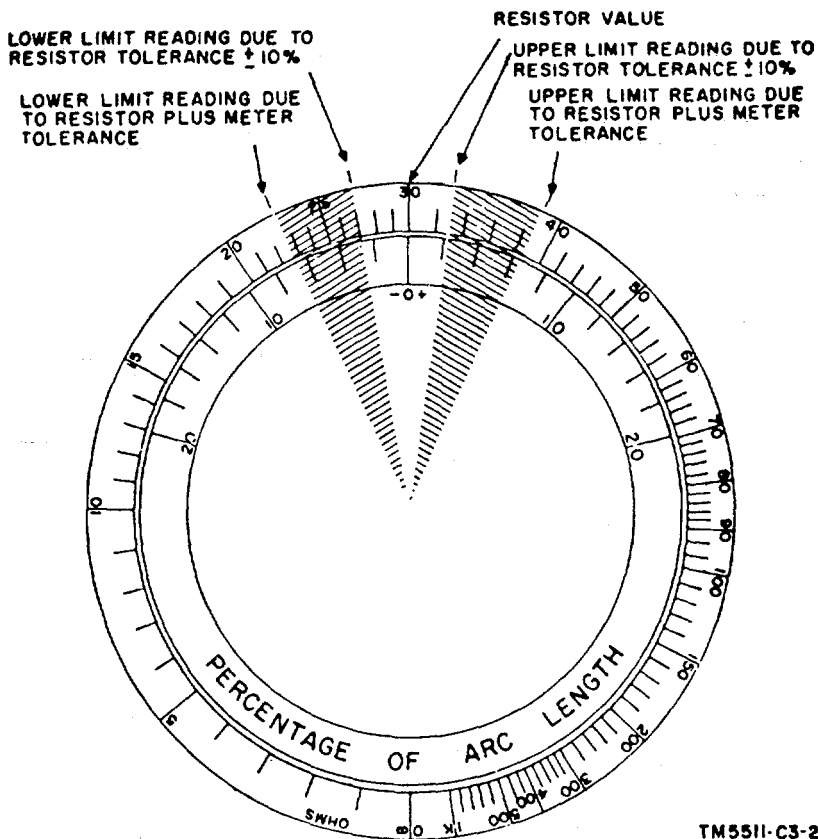

Figure 4.2. (Added) Computing device, indicating meter and resistance tolerance.

2. Calculation for ± 10 -percent resistor.
 - a. Compute resistor extremes.
 - b. These extremes are 27.0 ohms and 33.0 ohms.
 - c. Set ± 0 line to 27.0 ohms on the ohms scale and read the ohms value, two divisions to left of ± 0 .
 - d. This reading is 22.7 ohms (fig 4.2).
 - e. Set ± 0 line to 33.0 ohms on the ohms scale and read ohms value two divisions to right of ± 0 .
 - f. This reading is 38.1 ohms (fig. 4.2).

Page 23, paragraph 30c. Add the following caution after subparagraph (4).

Caution: Damage to switch contacts and wiring can result from leaking batteries. Inspect the batteries at least once each month or oftener during hot weather.

Page 26, paragraph 31, item No. 15, "Precautions" column. (As changed by C 2, 27 Oct 58) Add the following: For proper operation of Multimeter TS-505/U, the two glow tubes (voltage regulator tubes

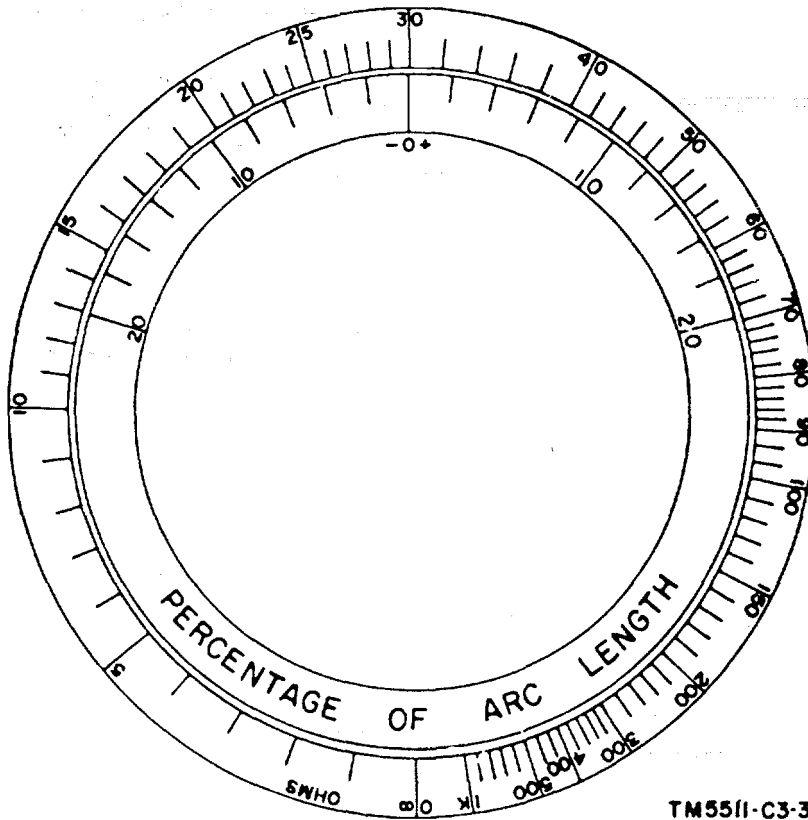

Figure 4.3. (Added) Computing device, for determining limits of acceptability for resistors tested with Electronic Multimeter TS-505/U.

V6 and V7) must be installed so that the *outer* spiral electrode glows during operation. To accomplish this, plug the power cord into an appropriate ac power source and operate the FUNCTION switch to OHMS. Wait the required warm-up time, and then check to see that the *outer* spiral electrodes of both tubes are glowing. If the inner electrode of either tube is glowing, remove that tube, rotate it 180°, and replace it in the socket.

Page 44, paragraph 50. (As changed by C 2, 27 Oct 68) After subparagraph a, add:

Note. Before making resistance measurements in a defective TS-50/U, disconnect the ac power source and remove the two BA-30 batteries from the battery compartment.

Page 55, figure 17 (page 10 of C 1). (As changed by C 2, 27 Oct 58) At pin 1 of tube socket V2 6AL5, change "-.2V" to read: 0.

Page 67. Appendix II was deleted by C 2, 27 Oct 68.

By ORBDB OF THE SECRETARISB OF THE ARMY AND THE AIR FORCE:

L. L. LEMNITZER,
*General, United States Army,
chief of Staff.*

OFFICIAL:

R. V. LEE,
*Major General, United States Army,
The Adjutant General.*

OFFICIAL

J. L. TARR,
*Colonel, United Sates Air Force,
Director of Administrative Services.*

THOMAS D. WHITE
Chief of Staff, United State Air Force.

DISTRIBUTION

Active Army:

To be distributed in accordance with DA Form 12-7 requirements for TM 11 Series (UNCL) plus the following additional formula:

USASA (2)	11-97
CNGB (1)	11-98
Def Atomic Spt Agcy. (5)	11-117
Tech Stf, DA (1) except CSigO	11-155
(18)	11-157
USA Abn & Elct Bd (1)	11-158
USA ATB (1)	11-500 (Tms AA-AE)
UARADCOM (2)	11-555
US ARADCOM Rgn (2)	11-557
MDW (1)	11-558
Seventh US Army (5)	11-587
EUSA (5)	11-592
Corps (2)	11-597
JBUSMC (2)	11-608
Units orgauix7ed under following	17
TOE's: (2 copies each)	17-51
1-7	29-51
1-17	29-55
1-37	29-56
1-67	29-57
1-107	32-51
5-8	32-55
5-278	32-56
5-500 (Tms AA-AD)	32-57
5-600	32-500
5-605	33-56
6-100	33-57 (Tms AA-AC)
6-101	39-51
6-300	39-52
6-301	39-61
6-315	44-12
6-316	44-101
6-630	44-535
7	44-537
7-52	44-545
9-217	44-546
9-510	44-547
11-5	44-548
11-6	44-535
11-7	44-537
11-8	44-544
11-15	44-545
11-16	44-546
1138	44-547
11-55	44-548
11-56	44-549
11-57	55-157
11-58	57

NG: State AG (3); units-same as Active Army except allowance is one copy each.

USAR: None.

For explanation of abbreviations used, see AR 320-50.

ELECTRONIC MULTIMETER TS-505/U

TM 11-5511
 TO 33A1-12-55-1
 CHANGES No. 1 }
 }
 }
 }

DEPARTMENTS OF THE ARMY AND
 THE AIR FORCE
 WASHINGTON 25, D. C., 21 November 1956

TM 11-5511, 8 June 1951, is changed as follows:

Page 2, paragraph 3c (3). Make the following changes:

Line six. Change "500 mc/s" to read: **10 mc.** (3.1) (Added) There are five RF voltage ranges which permit measurement of voltages from .05 to 40 volts. The RF voltage measurement is accurate from 10 me to 500 mc.

Page 4, paragraph 4. Make the following changes in the table: After "2 test leads (black)" add:

Component	Length (in.)	Width (in.)	Depth (in.)	Volume (cu ft)	Weight (lb)
1 rf adapter (Test Prod MX-1797/U).	3%	5/8			

In the *Component* column, change "8 tubes" to read: 7 tubes. Paragraph 5a.

(11) (Superseded) An RF adapter is supplied with the multimeter. The RF adapter is attached to the end of the DC PROBE to increase the ac (rf) range.

Page 6, paragraph 7. Make the following changes in the right column:

"Number of ranges" indication. Line 4. Before "seven" add: five rf voltage ranges (0 to 2, 0 to 4, 0 to 10, 0 to 20, 0 to 40).

"Number of tubes". Change "eight" to read: seven.

"Types of tubes". Delete: Probe 1-RMA No. 5935. After "Diode balancing" add: and ac signal rectifier.

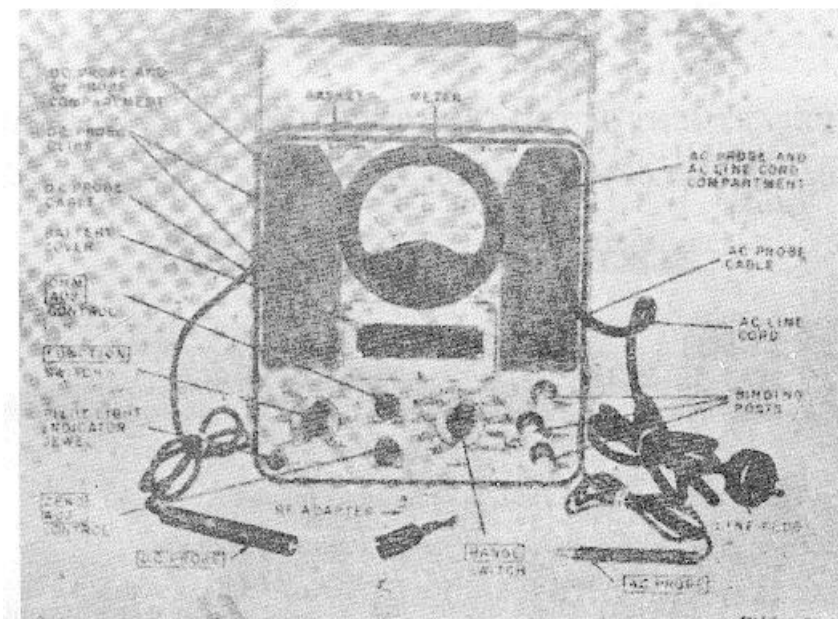

Figure 3. (Superseded) Electronic Multimeter TS-505/U, front panel.

11. Repacking (Superseded)

a. Before repacking the multimeter for storage or shipment, remove it from service.

(1) Remove the battery cover (fig. 3) from the front panel of the multimeter.

(2) Remove the batteries from the battery compartment.

(3) Clean the battery compartment (par. 30c(3.1)) if necessary and replace the battery cover.

b. Repack the multimeter in the same manner as it was originally packed by reversing the unpacking procedure (par. 9).

Page 11, paragraph 12b. Add the following after the last sentence: Place two batteries (Bk-30) in the battery compartment (par. 19c).

Page 12, paragraph 15b. Make the following changes: Line 3. Change ".5 mc/s" to read: **10 mc**. Delete the last sentence.

(1.1) (Added) To measure RF voltages, connect the tip jacket of a test lead to the COMMON binding post (fig. 3). Connect the RF adapter to the end of the DC PROBE. Connect the other end of the RF adapter and the COMMON test lead

probe across the unknown voltage. Connect the alligator clip lead of the RF adapter to the low potential point on the equipment under test.

Page 15, paragraph 18a. (2) (Superseded) For RF voltage measurements (above 10 mc) refer to paragraph 18.1.

18.1 Reading and Measuring RF Voltages (Added)

Note. The procedures specified in this paragraph apply to measurement of RF voltages from 10 mc to 500 mc.

a. Reading RF Voltages. Read the RF voltages on the dc voltage scale of the meter (fig. 3). The most accurate readings are obtained when the meter pointer is within the upper one-third portion of the dc voltage scale.

b. Zeroing Meter for RF Measurements.

- (1) Perform the starting operations outlined in paragraph 16.
- (2) Turn the FUNCTION switch to the +DC position. (After the multimeter has warmed up, the meter pointer will probably be near, but not at, zero scale reading.)
- (3) Turn the RANGE switch to the 2V-RX1 position.
- (4) Hold the DC PROBE and the COMMON probe tips together, and turn the ZERO ADJ. control until the meter pointer indicates exactly 0 volt.

c. Measuring PF Voltages.

- (1) Turn the RANGE switch to a higher voltage scale than the voltage to be measured. If the magnitude of the voltage to be measured is unknown, turn the RANGE switch to the 40V-RX10K position. If necessary, the RANGE switch can be rotated to a lower scale. This procedure will protect the multimeter from a severe overload which might damage the meter movement when measuring RF voltages.

Caution: Do not attempt to measure RF voltages greater than 40 volts rms. The RF adapter will be damaged if greater voltages are applied.

- (2) Connect the DC PROBE tip to the end of the RF adapter.
- (3) Connect the alligator clip lead of the RF adapter to the low potential point of the voltage to be measured. (Do not add extra length to the alligator clip lead; extra length will cause RF loop effects.)
- (4) Connect the RF adapter tip to the high potential side of the RF voltage to be measured.

AGO 2910B

(5) Turn the RANGE switch counterclockwise, one position at a time until the meter pointer is within the upper one-third portion of the dc voltage scale.

(6) Read the meter.

Page 16, paragraph 20d. At the end of the paragraph add: If the multimeter is to be stored for more than 2 months remove the batteries from the battery compartment (par. 11a).

Page 18, paragraph 22. In the table after item 5 add:

Item No.	Switch setting		Action or condition	Normal indication	Corrective measure
	FUNCTION	RANGE			
5.1	+DC	2V-RX1	Connect rf adapter to DC PROBE. Set meter pointer to zero with rf adapter tip connected to COMMON binding post.	Rotation of ZERO ADJ. control Should set pointer at zero.	Replace rf adapter.
5.2	+DC	Any up to 40V-RX lox	Connect rf adapter to DC PROBE. Apply rf voltage between rf adapter and COMMON binding post.	Meter should indicate rf voltage.	Turn in equipment for repair.

Page 22, paragraph 30c.

(3.1) (Added) Remove the batteries from the battery compartment (par. 11a) and check the battery compartment for rust and corrosion. Replace the batteries if necessary (par. 19c). Clean the battery compartment with No. 0000 sand-paper and Cleaning Compound (Federal stock No. 7930-395-9542).

Warning: Prolonged breathing of Cleaning Compound fumes is dangerous. Make certain that adequate ventilation is provided. Cleaning Compound is flammable; do not use near a flame.

Page 24, paragraph 31. In the table, after item 6, add:

Item No	What to check	When to check	How to check	Precautions
6.1	Battery compartment.	Monthly.	Remove battery cover (fig. 3) and visually check for rust and corrosion.	Remove the rust or corrosion (par. 30c (8.1)).

33. Block Diagram (Superseded) (fig. 5)

a. *Function Switch.* The FUNCTION switch (S1) selects the particular circuit in the multimeter which will be used to measure resistance or voltage. In the OFF position, the switch disconnects the multimeter circuit from the power source.

b. *RANGE Switch.* The RANGE switch (S2) selects the proper voltage or resistance range.

c. *Input Coupling Amplifiers.* The input coupling amplifiers (V3 and V4) function as an impedance-matching network to convert the high input impedance to a low impedance for the meter circuit. The gain of these amplifiers is unity.

d. *Coarse Zero Adjust Control.* The coarse zero adjustment control (R14) compensates for large variations between the input coupling amplifier tubes (V3 and V4) and accomplishes coarse balancing of these tubes. Coarse balancing sets these tubes within the range of the ZERO ADJ. control.

e. *ZERO ADJ. Control.* The ZERO ADJ. control (R10) adjusts the zero setting of the meter pointer with no voltage input by balancing the outputs of the two input coupling amplifiers (V3 and V4).

f. *Output Coupling.* The output coupling tube (V5) is a twin-triode, which couples the output from the plate of the input coupling amplifiers to the meter, with negligible loading.

g. *Voltage Regulators.* The voltage regulator tubes (V6 and V7) provide a low-resistance coupling from the output coupling tube (V5) to the meter (M1).

h. *Zero Center Control.* The zero centering control (R8) regulates the voltage drop across the meter (M1) when measuring +DC voltages, and thus provides for coarse zero adjustment of the meter pointer.

i. *Power Supply.* The power supply (V8) furnishes the necessary operating potentials to the other tubes in the circuit.

j. *DC PROBE.* The DC PROBE (E4) contains an isolating resistor to prevent capacitive loading of the circuit under test by the multimeter.

k. *RF Adapter.* The RF adapter is used with the dc voltage measurement circuit to measure RF voltages of frequencies from 10 mc to 500 mc. A germanium diode and a coupling capacitor within the RF adapter, rectify the applied RF voltage into a dc voltage.

AGO 2910B

l. AC PROBE. The AC PROBE (E5) contains an isolating resistor to prevent capacitive loading of the circuit under test by the multimeter. Ac voltages at frequencies between 30 cps and 10 mc may be measured through the AC PROBE.

m. Ac Signal Rectifier. The ac signal rectifier (V2A) rectifies the input ac voltage being measured (from .30 cps to 10 mc) and supplies a pulsating dc voltage to the input coupling amplifiers.

n. Balancing Diode. The balancing diode (V2B) supplies a voltage that is proportional to the ac input voltage being measured. This voltage bucks out the contact potential of the ac signal rectifier (V2A).

o. Ac Zero Control. The ac zero control (R39) varies the amount of bias applied to the input coupling amplifiers (V3 and V4) from the action of the balancing diode (V2B).

p. Ac Calibration. The ac calibration control (R5) regulates the voltage drop across the meter when measuring ac voltages, and thus provides for coarse zero adjustment of the meter pointer.

q. OHMS Binding Post. The OHMS binding post (E1) provides an external connection to the ohmmeter circuit.

r. Ohmmeter Batteries. The two ohmmeter batteries (BA30) provide a source of constant dc voltage to the ohmmeter circuit. This dc voltage is applied across the unknown resistance to be measured. The voltage drop across the unknown resistance is indicated by the meter as a resistance reading.

s. OHMS ADJ. Control. The OHMS ADJ. control (R3) adjusts the meter pointer to full-scale reading ∞ on the OHMS scale by varying the amount of resistance in series with the meter.

t. COMMON Binding Post. The COMMON binding post (E2) provides an external connection for the common circuit of the multimeter.

u. CASE Binding Post. The CASE binding post (E3) provides an external connection for grounding the multimeter case to reduce the effect of external fields and to reduce shock hazard.

v. Meter. The meter (M1) is a 0- to 1-milliampere movement (infinite damping factor) with the appropriate measurement scales (fig. 3) printed on the face. Change "V2" to "V2B (1/2-6AL5)" in the following places in the manual:

Page 32, paragraph 37a, Line 14. paragraph 37b, Line 6. paragraph 37b (3), Lines 2, 5, and 7.

AGO 2910B

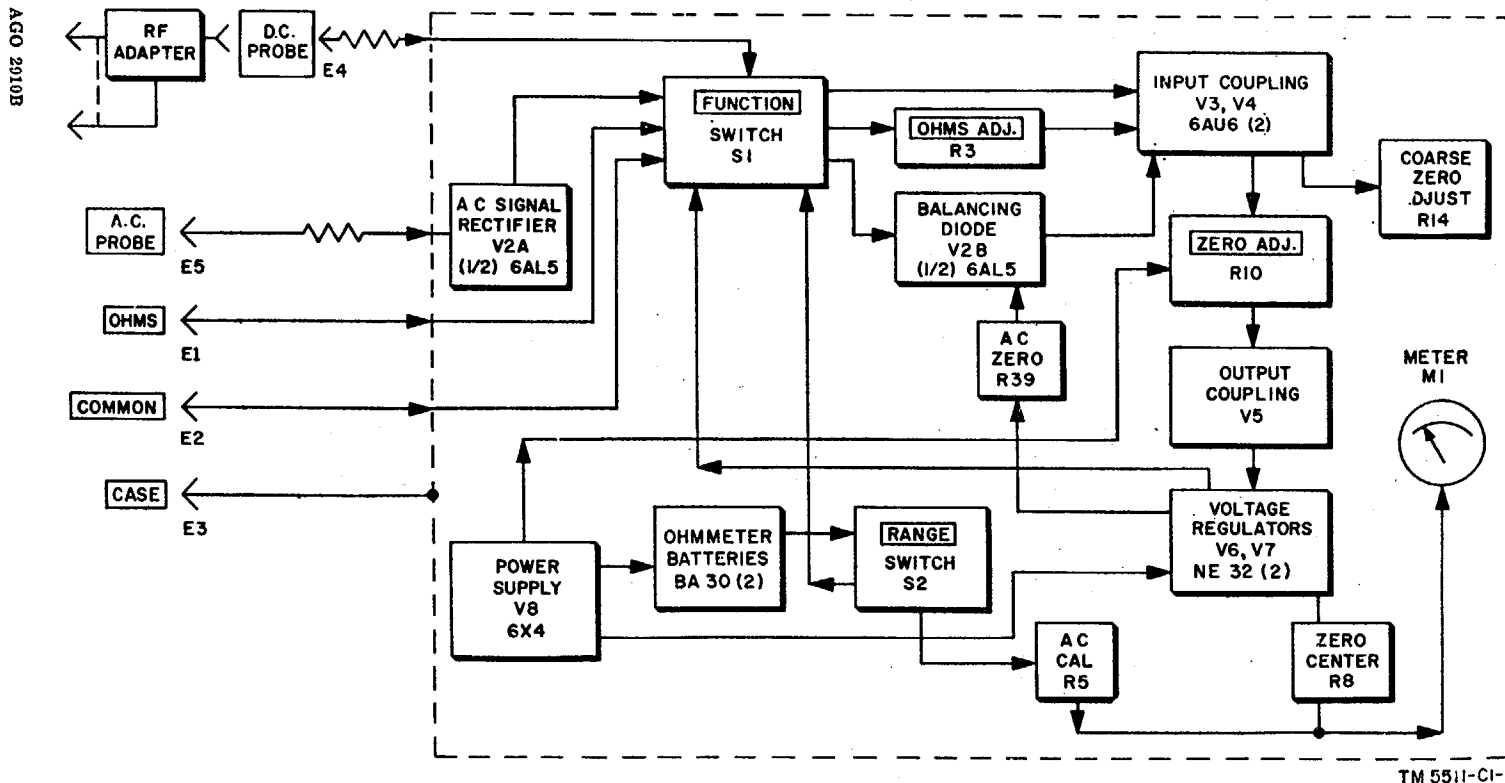

Figure 5. (Superseded) Electronic Multimeter TS-505/U, block diagram.

Page 34, Figure 10. Change "a-c probe" to "ac signal rectifier" in the following places in the manual.

Page 32, paragraph 37a, Line 9 and 12. paragraph 37b, Line 7.

Page 42, paragraph 47c. Line 5, after "nonfunctioning".

Page 32, paragraph 37b(3). In lines 2 and 9 change "V1" to read: V2A (1/2-6AL5).

Page 35, paragraph 39.

a. (Superseded) The AC PROBE (fig. 22) contains a resistor (R1) mounted in the holder. The resistor prevents capacitive loading the circuit under test by the multimeter. The ac circuit, consisting a diode (V2B, 1/2-6AL5) connected in the circuit as a half-wave rectifier and input coupling capacitor (C2), and an input resistor (R45), permits accurate measurements up to 10 mc. Because of the high value of the input resistor (15 megohms) and the input capacitor (10,000 $\mu\mu\text{f}$), the diode is essentially a peak rectifier. Diode V2A (1/2-6AL5) acts as a balancing diode and is used to oppose the contact potential of diode V2B with no input signal applied to the AC PROBE. This balancing is accomplished by rotating resistor R39 until zero deflection on the meter is attained, with the AC PROBE tip connected to the COMMON binding post.

39.1 RF Voltage Measurement Circuit (Added)

a. Except for the addition of the RF adapter (fig. 11), the RF voltage measurement circuit is the same as the dc measurement circuit described in paragraph 37.

b. When in use, the RF adapter is connected to the DC PROBE. The RF adapter functions as a half-wave rectifier to convert the RF voltage being measured to a pulsating dc voltage.

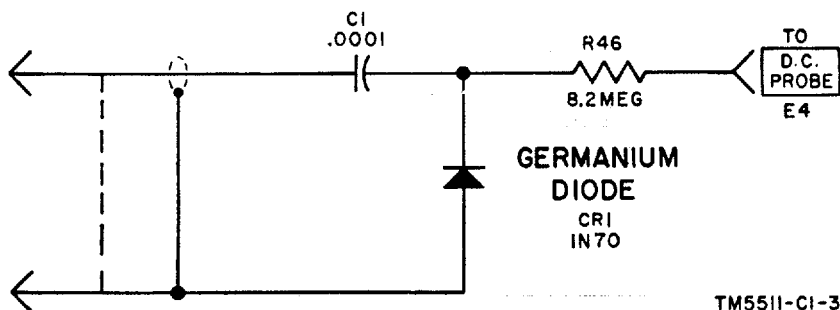

Figure 11. (Superseded) RF adapter, schematic diagram.

Page 37, paragraph 42a. At the end of the second sentence delete "(fig. 12)".

Page 38, figure 12. Rescinded.

Page 61, figure 20. Rescinded.

Page 62, figure 21. Rescinded.

Page 39, figure 13. Add the following Note:

NOTE: SPARE DIODE ASSEMBLIES ARE NOT SUPPLIED WITH THE TS-505/U.

Page 44, paragraph 50b. Make the following changes in the table: After item 15 add:

Switch position		Abnormal indication	Probable fault	Remedial action
S1	S2			
15.1 +DC.	Any up to 40V-RX10K.	No deflection of meter pointer (with rf adapter connected to DC PROBE, and rf voltage up to 40 volts, 10 me to 500 me applied).	a. Capacitor C1 open or shorted. b. Germanium diode CR1 open or shorted. c. Resistor R46 open.	a. Replace rf adapter. b. Replace rf adapter. c. Replace rf adapter.

Item 31. Delete.

Make the following changes in the *Probable fault* column:

Item 23a. Change "R1" to read: Resistor R45.

Items 24a and 25. Change "C1" to read: Capacitor C2.

Items 24b and 28a. Change "V1" to read: Tube V2.

Make the following changes in the *Remedial action* column:

Item 23a. Change "with spare diode assembly" to read: **resistor R45**.

Items 24a and 25. Change "a-c probe assembly" to read: capacitor C2.

Items 24b and 28a. Change "with spare diode assembly" to read: tube V2.

Item 28b. Delete.

Item 28c. Change "with spare diode assembly" to read: **resistor R1**.

AGO 2910B

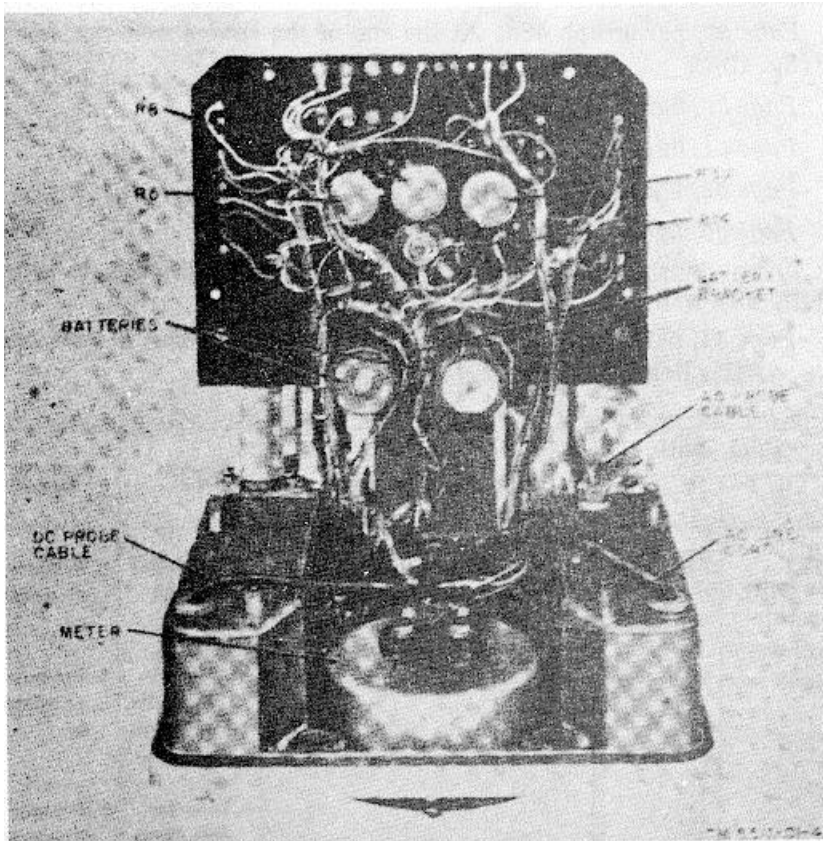

Figure 15. (Superseded) Electronic Multimeter TS-505/U, under side of terminal board.

Page 54, figure 16. On tube socket V2 6AL5 make the following changes:

- Pin 1. Change "1,450" to read: 0.
- Pin 7. Change "3 MEG" to read: INFINITY.

Page 55, figure 17. On tube socket V2 6AL5 make the following changes:

- Pin 1. Change "0" to read: -.2V.
- Pin 2. Change "-.5V" to read: -.25V.

Page 59, paragraph 53. Rescinded.

Page 68, paragraph 56a. a.1. (Added) Remove the batteries from the compartment (par.11a).

Page 67. Appendix II. Rescinded.

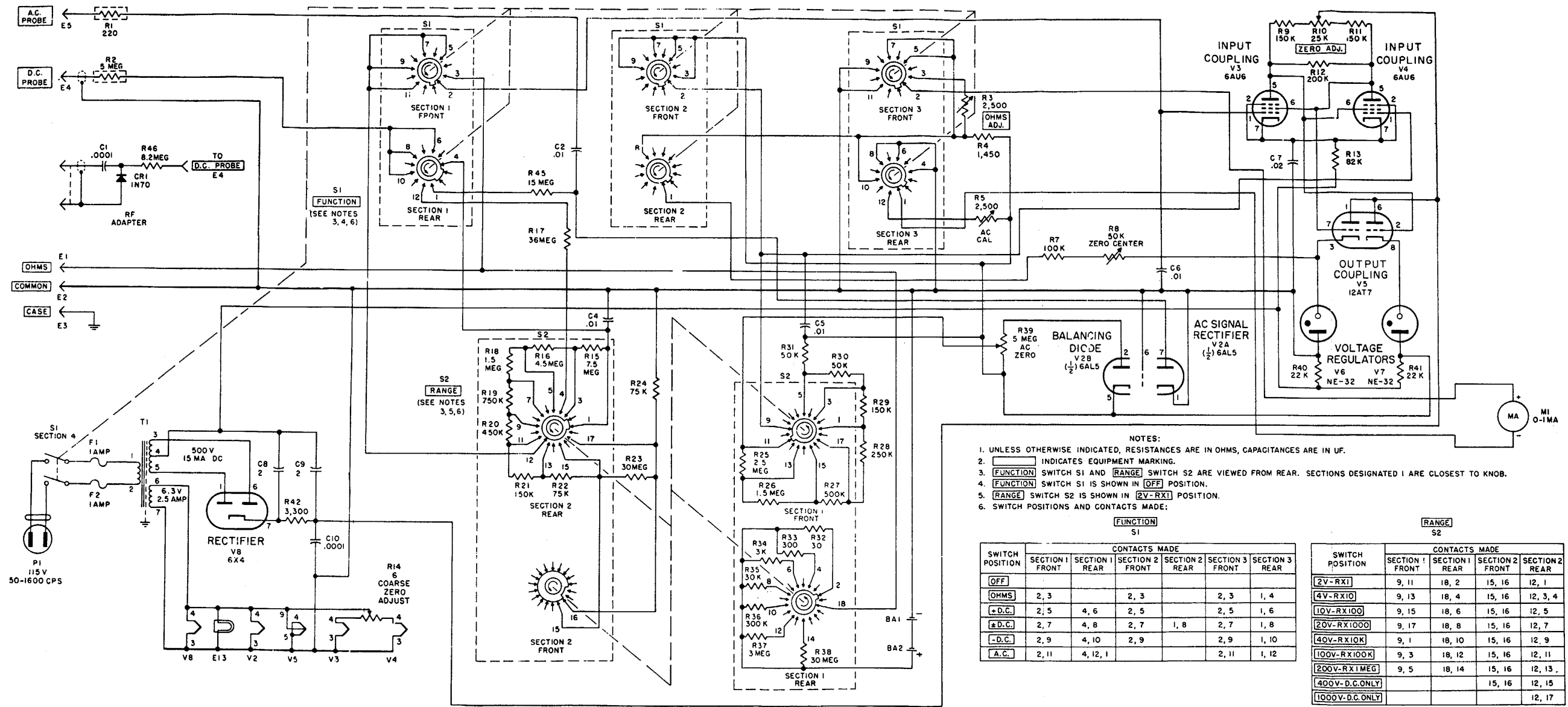

Figure 22. (Superseded) Electronic Multimeter TS-505/U, schematic diagram.

Figure 22. (Superseded) Electronic Multimeter TS-505/U, schematic diagram.

[AG 413.6 (8 Nov 56)]

BY ORDER OF THE SECRETARIES OF THE ARMY AND THE AIR FORCE:

MAXWELL D. TAYLOR,
*General, United States Army,
Chief of Staff.*

OFFICIAL:

JOHN A. KLEIN,
*Major General, United States Army,
The Adjutant General.*

N. F. TWINING,
Chief of Staff, United States Air Force.

OFFICIAL:

E. E. TORO,
*Colonel, United States Air Force,
Air Adjutant General.*

Distribution:

Active Army:

CNGB (1)	OS Sup Agencies (2)
ASA (3)	WRAMC (5)
Tec Svc, DA (1) except	Army Elct PG (1)
CISGO (30)	Aberdeen PG (5)
Tec Svc Bd (1)	Jefferson PG (5)
Hq CONARC (5)	Redstone Arsenal (5)
CONARC Bd (Incl ea test	Sig Fld Maint Shops (3)
sec) (1)	Sig Lab (5)
Army AA Comd (2)	ACS (3)
OS Maj Comd (5)	Mil Dist (1)
OS Base Comd (5)	Units org under fol TOE:
Log Comd (5)	5-278R (2)
MDW (1)	5-500R (AA-AD) (2)
Armies (5)	9-510R (2)
Corps (2)	11-7C (2)
Inf Div (2)	11-15C (2)
Armd Div (2)	11-16C (2)
Ft & Cp (2)	11-18C (2)
Sp Wpn Comd (2)	11-57C (2)
Army Cml Cen (9)	11-127R (2)
USMA (5)	11-128C (2)
Gen & Br Svc Sch (5) ex-	11-500R (2)
cept Sig Sch (25)	11-557C (2)
Gen Depot (2) except	11-587R (2)
Atlanta Gen Depot	11-592R (2)
(none)	11-597R (2)
Sig Sec, Gen Depot (10)	32-51R (2)
Sig Depot (17)	32-55R (2)
US Army Tng Cen (2)	32-56R (2)
PSYWAR Cen (5)	32-57R (2)
POE (OS) (2)	32-500R (2)
Trans Terminal Comd (2)	33-67R (2)
Army Terminal (2)	

NG: State AG (6); units-same as Active Army except allowance is one copy per unit.

USAR: None.

For explanation of abbreviations used, see SR 320-50-1.

DEPARTMENT OF THE ARMY TECHNICAL MANUAL

TM 11-5511

ELECTRONIC
MULTIMETER
TS-505/U

DEPARTMENT OF THE ARMY • JUNE 1951

United States Government Printing Office
Washington: 1951

DEPARTMENT OF THE ARMY
WASHINGTON 25, D. C., 8 June 1961

TM 11-5511 is published for the information and guidance of all concerned.
[AG 418.6 (1 Jun 51)]

BY ORDER OF THE SECRETARY OF THE ARMY:

OFFICIAL:

WM. E. BERGIN
Major General, USA
Acting The Adjutant General

J. LAWTON COLLINS
Chief of Staff, United States Army

DISTRIBUTION

Tech Svc (2) except 11 (65); Arm & Svc Bd (1); AFF Bd (ea Svc Test Sec) (1); AFF (5); AA Comd (2); OS Maj Comd (5); Base Comd (5); MDW (5); Log Comd (5); A (20); CHQ (2); FC (2); Sch (2) except 11 (25); Gen Dep (2); Dep 11 (20) except Sig Sec, Gen Dep (10); Tng Div (2); PE (10), OSD (2); Lab 11 (5); 4th & 5th Ech Maint Shops 11 (3); Two (2) copies to each of the following T/O & E's: 11-107; 11-127; 11-500 CA, CB, CC; 11-587; 11-592; 11-597; SPECIAL DISTRIBUTION.

For explanation of distribution formula, See SR 310-90-1.

CONTENTS

		<i>Paragraph</i>	<i>Page</i>
CHAPTER	1. INTRODUCTION.		
<i>Section</i>	<i>I</i> General.		
	Scope	1	1
	Forms and records	2	1
	<i>II.</i> Description and data.		
	General.....	3	3
	Table of components parts	4	4
	Component parts, description and location	5	4
	Accessory equipment.....	6	6
	Technical characteristics	7	6
	Packaging data	8	7
CHAPTER	2. OPERATING INSTRUCTIONS.		
<i>Section</i>	<i>I.</i> Service upon receipt of equipment.		
	Unpacking and checking new equipment.....	9	9
	Unpacking and checking used or recondition equipment.....	10	10
	Repacking.....	11	10
	Location	12	11
	<i>II.</i> Controls and instruments.		
	Controls	13	11
	Meter	14	12
	Panel connections.....	15	12
	<i>III.</i> Operation under usual conditions.		
	Preliminary starting procedure	16	12
	Measuring and reading d-c voltages.....	17	14
	Measuring and reading a-c voltages	18	15
	Measuring and reading resistance, and adjusting ohms scale	19	15
	Stopping procedure.....	20	16
	Purpose and use of equipment performance checklist.....	21	16
	Equipment performance checklist.....	22	18
	<i>IV.</i> Operation under unusual conditions.		
	General.....	23	20
	Batteries	24	20

CHAPTER 3. MAINTENANCE INSTRUCTIONS.

	<i>Paragraph</i>	<i>Page</i>
<i>Section I.</i> Lubrication and preservation.		
Lubrication	25	21
Weatherproofing	26	21
Rustproofing and painting	27	21
<i>Section II.</i> Preventive maintenance services.		
Definition and importance of preventive maintenance	28	22
General preventive maintenance techniques	29	22
Specific preventive maintenance techniques	30	22
Preventive maintenance checklist.....	31	23

CHAPTER 4. FIELD MAINTENANCE INSTRUCTIONS.

<i>Section I.</i> Theory of operation.		
Scope and application.....	32	27
Block diagram	33	27
Power supply	34	29
Amplifier	35	30
Indicating meter	36	32
Switch section.....	37	32
D-c probe.....	38	35
A-c probe.....	39	35
<i>Section II.</i> Prerepair procedures.		
Tools, materials, and test equipment	40	37
Power requirements	41	37
Inspection	42	37
Removal of pluck-out parts.....	43	38
Stripping	44	39
Cleaning	45	41
<i>Section III.</i> Trouble location.		
Preliminary procedure.....	46	42
Trouble-shooting procedures.....	47	42
Gas checks.....	48	43
General precautions.....	49	43
Trouble-shooting chart	50	44
<i>Section IV.</i> Calibration procedures.		
General.....	51	58
Setting zero controls	52	58
Replacement of a-c probe assembly.....	53	59

	<i>Paragraph</i>	<i>PF0g</i>
V. Refinishing.		
Appearance.....	54	61
Refinishing after repair.....	55	61
CHAPTER	5. SHIPMENT AND LIMITED STORAGE AND DEMOLITION TO PREVENT ENEMY USE.	
<i>Section</i>	<i>I.</i> Shipment and storage.	
	Removal from service	63
	Repacking for shipment or limited storage	63
	<i>II.</i> Demolition to prevent enemy use.	
	Methods of demolition	63
	Destruction of components.....	64
APPENDIX	I. REFERENCES	65
	II. IDENTIFICATION TABLE OF PARTS FOR ELECTRONIC MULTIMETER TS-505/U	67
INDEX	75

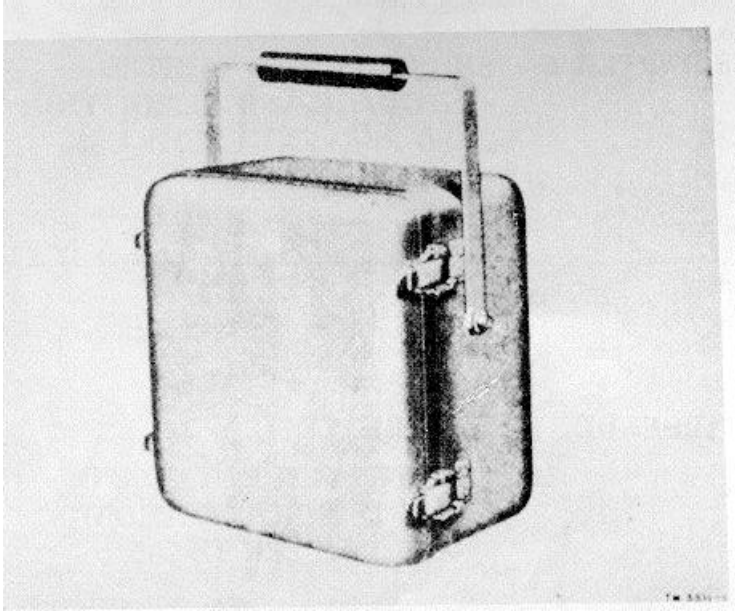

Figure 1. Electronic Multimeter TS-505/U.

CHAPTER 1 INTRODUCTION

Section I. GENERAL

1. Scope

a. These instructions are published for the information and guidance of the personnel to whom this equipment is issued. They contain a physical description of the equipment; information on operation, organizational maintenance, theory, and field maintenance; instructions for removing the equipment from service and repacking for shipment or limited storage; and instructions for demolishing the equipment to prevent enemy use. These instructions apply only to Electronic Multimeter TS-505/U.

b. Appendix I contains a list of references, including supply catalogs, technical manuals on associated equipment, and other available publications applicable to the equipment. Appendix II contains an identification table of parts.

2. Forms and Records

The following standard forms will be used for reporting unsatisfactory conditions of equipment, or improper preservation, packaging, packing, marking, loading, stowage, or handling thereof.

a. DD Form 6, Report of Damaged or Improper Shipment (Reports Control Symbols CS GLD-66 (Army), S and A-70-6 (Navy), and AF-MC-U2 (Air Force)), will be filled out and forwarded as prescribed in SR 745-45-5 (Army), NAV DEPT SERIAL 85POO (Navy), and AFR 71-4 (Air Force).

b. DA AGO Form 468, Unsatisfactory Equipment Report (Reports Control Symbol CS GLD-247), will be filled out and forwarded to the Office of the Chief Signal Officer as prescribed in SR 700-45-5.

- c. AF Form 54, Unsatisfactory Report, will be filled out and forwarded to Commanding General, Air Material Command, Wright-Patterson Air Force Base, Dayton, Ohio, as prescribed in SR 700-45-5 and AFR 65-26.
- d. Use other forms and records as authorized.

Section II. DESCRIPTION AND DATA

3. General

a. DESCRIPTION OF ELECTRONIC MULTIMETER. (1) Electronic Multimeter TS-505/U is a general purpose a-c (alternating-current) and d-c (direct-current) vacuum-tube voltmeter and a d-c ohmmeter. It is a self-contained unit.

(2) The cover of the multimeter is attached with four spring catches (fig. 2). Two sets of test leads for use with the multimeter are contained in the cover. The handle may be pivoted and locked into position to act as a stand, thus permitting the operator to place the multimeter at a comfortable viewing angle (fig. 2). Six screws are used to attach the rear cover of the multimeter. These screws serve as legs which protect the meter case when it is placed in a horizontal position.

(3) The multimeter is made completely watertight by means of two peripheral rubber gaskets (on the back and on the front of the front panel); by rubber gaskets behind the meter and the battery cover; and by O rings, or washers, behind the potentiometers, the switches, the binding posts, and the pilot light indicator jewel.

b. PURPOSE AND USE. Electronic Multimeter TS-505/U is used when testing electronic equipment. It permits the measurement of ac and d-c voltage and resistance over relatively wide ranges.

c. EQUIPMENT FEATURES. (1) Voltages and resistances are measured by a specially calibrated milliammeter. The d-c and a-c voltages are read on the outer arc (black) of the scale (fig. 3). The resistance scale is the second largest arc (green). The zero center d-c scale is the third largest arc (blue). The 0- to 2-volt a-c range is the innermost arc (purple). The meter is hermetically sealed.

(2) There are nine d-c voltage ranges which permit measurement of voltages from .05 to 1,000 volts. The appropriate voltage range is selected with the RANGE switch. The input resistance is 20 megohms on all d-c voltage ranges except the 1,000-volt range; for the 1,000-volt range, the input resistance is increased to 50 megohms.

(3) There are seven a-c voltage ranges which permit measurement of voltages from .05 to 200 volts. The appropriate voltage range is selected with the RANGE switch. The input capacity is 2 uuf (micromicrofarads) shunted by a resistance greater than 6 megohms over the audio range.

The maximum input is 200 volts rms (root mean square). The a-c voltage measurement is accurate from 30 cps (cycles per second) to 500 mc/s (megacycles per second). The multimeter is a peak-indicating voltmeter. Note, however, that the meter scale is calibrated to read rms volts, and it will indicate correctly for a sine wave input only. Refer to paragraph 39b for information concerning the effect of nonsinusoidal voltages.

(4) The ohmmeter permits the measurement of resistances from 1 ohm to 1,000 megohms. There are seven resistance ranges with midscale readings of 30 ohms and multiples thereof. The highest resistance range can be used to measure insulation resistance.

(5) The zero center d-c scale permits the measurement of d-c voltage of unknown polarity. The appropriate polarity to be determined depends on probe polarity and on which direction the meter needle deflects (+d c if the meter needle swings to the right and -d c if the meter needle swings to the left). If accuracy greater than that obtainable on the zero center scale is desired, the FUNCTION switch may be set to the appropriate polarity. The voltage may then be read on the outer scale. The zero center d-c scale may be used in aligning the discriminators of frequency-modulated receivers.

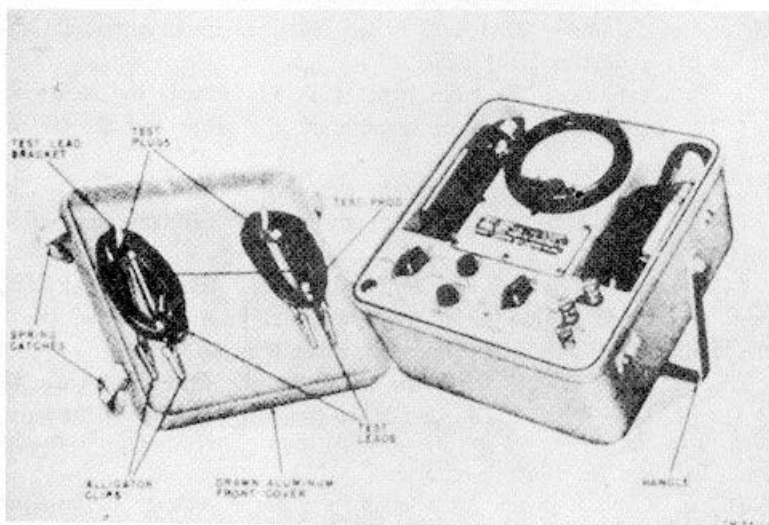

Figure 2. Electronic Multimeter TS-505/U, with handle locked in position.

4. Table of Component Parts

Component	Length (in.)	Width (in.)	Depth (in.)	Volume (cu ft)	Weight (lb)
Electronic Multimeter TS-505/U containing: 1 milliammeter.	10	9½ Flange: 4½ Body: 3⅞	6¼ 2	.34	15
2 test leads (red).	48				
2 test leads (black).	48				
4 alligator clips.	2	7/16	5/16		
1 pilot light (6.3 v, .15 amp).					
4 fuses (3AG, 1 amp).	1¼	¼			
8 tubes.					

Note. This list is for general information only. See appropriate publications for information pertaining to requisition of spare parts.

5. Component Parts, Description and Location

Electronic Multimeter TS-S05/U is self-contained in an aluminum case which has a die-cast front panel.

a. FRONT PANEL. The front panel (fig. 3) includes the following:

- (1) A compartment for storing both the d-c probe and the a-c line cord.
- (2) A compartment for storing the a-c probe.
- (3) A 0- to 1-ma (milliampere) meter calibrated for the various ranges.
- (4) Three binding-post type terminals for test leads. These binding posts are labeled OHMS, COMMON, and CASE. A rectangular slot in the binding posts will accept pin jacks, spade lugs, or wire.
- (5) A FUNCTION switch for switching the meter on when the A C, +D C, ±D C, -D C, or OHMS position is selected. This switch also turns the power off in the OFF position. The pointer on the bar knob indicates the function selected.
- (6) A RANGE switch for selecting the proper voltage or resistance range. The pointer on the bar knob indicates the range selected.
- (7) An ohmmeter adjusting control (OHM ADJ) to compensate for the decrease of the ohmmeter battery voltage.

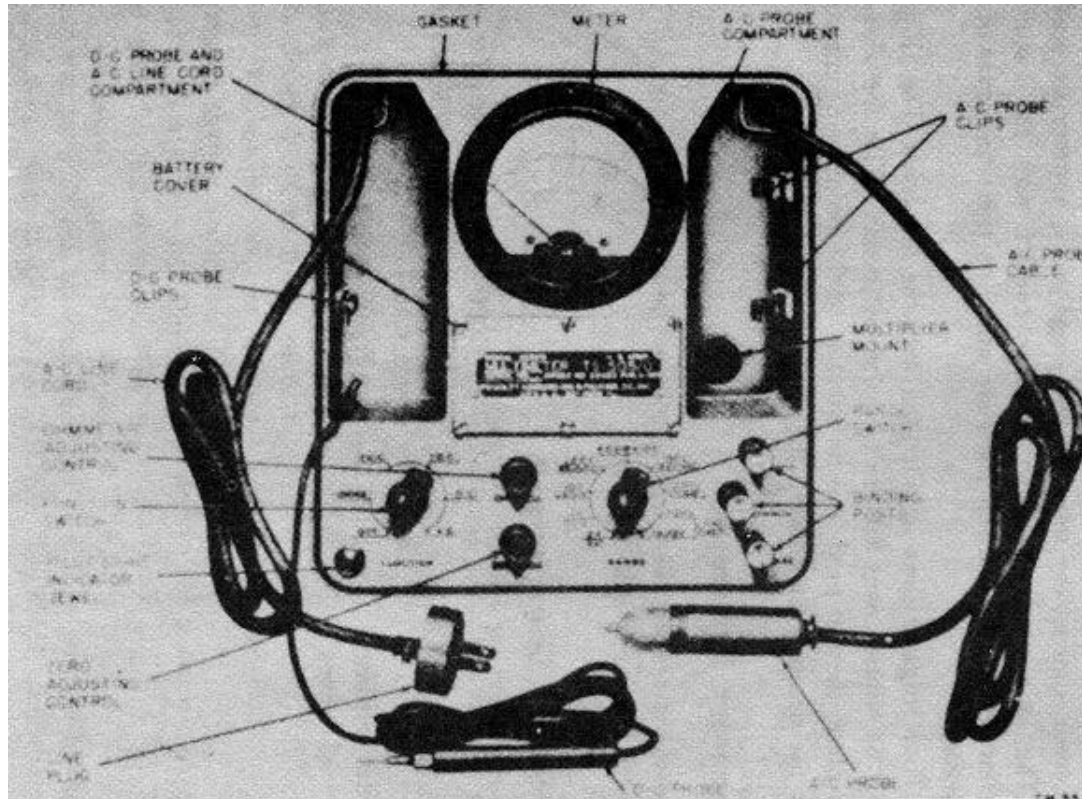

Figure 3. Electronic Multimeter TS-505/U, front panel.

- (8) A zero adjustment control (ZERO ADJ) to set the meter to zero.
- (9) A pilot light which lights when the FUNCTION switch is in any position except OFF.
- (10) A battery cover which covers the battery compartment.
- (11) A multiplier mount to hold the a-c probe multiplier. This mount

has a threaded screw to match that of the 10-to 1-voltage multiplier which is used to increase the range of a-c measurements.

b. TEST LEADS. (1) Two sets of test leads are supplied with the multimeter. (A set of test leads consists of two leads: 1 red, 1 black.) One set is used with the binding posts, the other is a spare set. To use the test leads, connect the short tip test plugs to the appropriate binding posts. The long prods are used to make contact with the circuit or component under test, The test leads are stored on the front cover of the multimeter.

(2) Four alligator clips are supplied with the test leads. The alligator clips can be slipped over the ends of the test prods. With the alligator clips in place, the test prods can be attached to the point being measured without the necessity of holding the test prod.

6. Accessory Equipment

No accessories are supplied with Electronic Multimeter TS-505/U. The multimeter is entirely self-contained.

7. Technical Characteristics

Voltage range	0 to 1,000 volts dc, 0 to 200 volts ac rms, 0 to ± 500 volts dc (zero center scale).
Ohmmeter range	0 to 1,000 megohms.
Number of ranges nine d-c voltage ranges (0 to 2, 0 to 4, 0 to 10, 0 to 20, 0 to 40, 0 to 100, 0 to 200, 0 to 400, 0 to 1,000); seven a-c voltage ranges (0 to 2, 0 to 4, 0 to 10, 0 to 20, 0 to 40, 0 to 100, 0 to 200); nine zero center d-c voltage ranges (-1 to +1, -2 to +2, -5 to +5, -10 to +10, -20 to +20, -50 to +50, -100 to +100, -200 to +200, -500 to +500); seven resistance ranges (0 to 1,000 ohms with 30-ohm center scale; 0 to 10,000 ohms with 300-ohm center scale; 0 to 100,000 ohms with 3,000-ohm center scale; 0 to 1 megohm with 30,000-ohm center scale; 0 to 10 megohms with 300,000-ohm center scale; 0 to 100 megohms with 3-megohm center scale; 0 to 1,000 megohms with 30-megohm center scale).

Number of tubes	eight.
Types of tubes	
Probe.....	1-RMA No.5935.
Amplifier	2-type 6AU6.
Regulator.....	2-type NE-32.
Meter output	1-type 12AT7.
Diode balancing.....	1-type 6AL5.
Rectifier	1-type 6X4.
A-c line voltage input.....	100 to 130 volts, 50 to 1,600 cps.
A-c power input.....	approximately 20 va (volt-amperes).
Battery supply.....	2-BA-30 (11/2 volts) for ohmmeter
Accuracy.....	±4%of full scale on dc voltage; 6% of full scale for a-c sinusoidal input from 30 cps to 500 mc/s; ±4 of ohmmeter arc length on ohms scale.
Frequency range	30 cps to 500 mc/s.
Input impedance	at least 6 megohms shunted by 2 uuf at af (audio frequencies); 50 megohms on 1, 000 volts d-c range, and ± 500 volts d-c range; 20 megohms on all other d-c ranges.
Indicating meter	1 ma dc for full-scale deflection.

8. Packaging Data

Electronic Multimeter TS-505 U is individually wrapped in a waterproof, fiberboard container and packed in a fiberboard packing case (fig. 4). The dimensions and weight of the multimeter packaged complete with tubes and technical literature are shown in the table below.

Component	Length (in.)	Width (in.)	Depth (in.)	Volume (cu ft)	Shipping wt. (lb)
Electronic Multimeter TS-505/U with tubes and test leads.	13	13	11¼	1.09	23

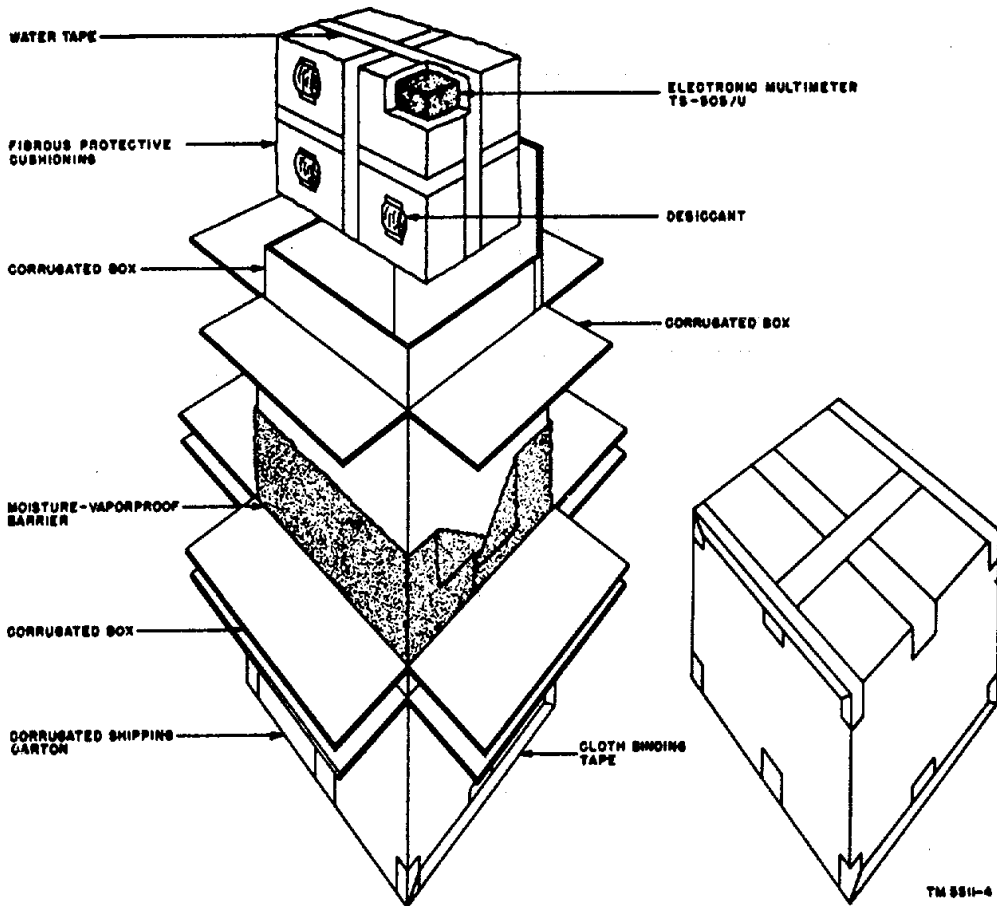

Figure 4. Electronic Multimeter TS-505/U, packing details.

CHAPTER 2 OPERATING INSTRUCTIONS

Section I. SERVICE UPON RECEIPT OF EQUIPMENT

9. Unpacking and Checking New Equipment

a. GENERAL. Equipment may be shipped in oversea packing cases, in domestic packing cases, and, sometimes, in its own carrying case. When new equipment is received, select a location where the equipment may be unpacked without exposure to the elements and which is convenient to the permanent or semipermanent installation of the equipment. Use care when unpacking or handling the equipment. It is a precision measuring instrument, and mishandling will make the set inaccurate or inoperative.

b. STEP-BY-STEP INSTRUCTIONS FOR UNPACKING AND CHECKING. Be careful when unpacking the equipment. Avoid thrusting tools into the interior of the container. Follow the steps outlined below when unpacking the multimeter.

(1) Place the packing case (fig. 4) in a convenient location where it may be opened easily.

(2) Cut the cloth binding which seals the exterior carton in such a manner as to leave the carton undamaged. Open the carton. Remove the inner corrugated box and open it.

(3) Lift the moisture-vaporproof barrier from the carton. Open the side of the carton and pull out the inner carton.

(4) Carefully cut the tape sealing the inner fiberboard box so that the carton will not be damaged. Open the carton. Remove the inner corrugated box and open it.

(5) Remove the cushioning and desiccant from the inner fiberboard box.

(6) Carefully lift the multimeter from the inner carton and place it on a solid table or workbench.

(7) Place the cushioning and the cartons into the outer carton for future use. They can be used again when the multimeter is repacked for storage or shipment (ch. 5).

(8) Check the contents against the master packing slip and against the list of components in paragraph 4. The test leads will be found on the front cover.

c. INSPECTION. (1) Inspect the multimeter thoroughly. Make sure that it has not been damaged in shipment or during unpacking. Inspect the carrying handle to see that it swings freely on the pivot point and will lock in position (fig. 2) to support the meter in an inclined position.

(2) Check the four catches on the front cover. Remove the front cover by unfastening the catches.

Caution: Do not try to open the catches with your fingers. The springs are very strong and the sudden opening of the catch may cut your fingers. Insert a screw driver between the catch and the case and use it as a lever. Keep your fingers away from the vicinity of the catches. Hold one hand on top of the cover when releasing catches to prevent cover from being thrown by catch springs.

(3) The multimeter is shipped with the tubes installed. See that the tubes are seated firmly in their sockets *only if the multimeter is inoperative*. To inspect the tubes, the back cover must be removed. Refer to paragraph 42a for instructions.

(4) If inspection discloses that the multimeter has been damaged, fill out the proper forms and forward them through channels (par. 2).

Note. Electronic Multimeter TS-505/U has been moistureproofed and fungi. proofed. Do not remove any of the protective lacquer coating.

10. Unpacking and Checking Used or Reconditioned Equipment

a. Follow the instructions in paragraph 9 for unpacking and checking the multimeter.

b. Check the used or reconditioned equipment for tags or other indications pertaining to changes in the wiring of the equipment. If any changes in wiring have been made, note the change in this instruction book, preferably on the schematic diagram.

c. Check the operating controls for ease of rotation.

11. Repacking

Before reshipping to any distant point, disconnect and remove the equipment from service and repack it in the same manner as it was originally. Reverse the procedure discussed in paragraph 9 for repacking.

12. Location

- a. Place the multimeter on a flat bench or firm base close to an a-c outlet. There must be no strain or kinks in the line cord.
- b. The multimeter is designed for use on a 100- to 130-volt, 50- to 1,600-cps power source. *Do not plug it into any other power source.* Do not plug the multimeter into the line before performing the operations outlined in paragraph 16.

Section II. CONTROLS AND INSTRUMENTS

13. Controls (fig. 3)

a. FUNCTION SWITCH (S1). This is a six-position switch which is used to select any desired function. In addition, the switch controls the a-c input to the multimeter. The switch has stops at the extreme clockwise and counterclockwise positions. Detents on all settings insure that the switch will snap into position.

- (1) The extreme counterclockwise setting is the OFF position.
- (2) The first clockwise position is the OHMS position.
- (3) The second clockwise position is the +D C volts position.
- (4) The third clockwise position is the \pm D C volts position.
- (5) The fourth clockwise position is the -D C volts position.
- (6) The fifth (extreme) clockwise position is the A C volts position.

Caution: Do not try to force the switch beyond the OFF position in a counterclockwise direction, or beyond the A C position in a clockwise direction. This switch is not continuously rotatable.

b. RANGE SWITCH (S2). This is a nine-position switch. The RANGE switch selects the various voltage or resistance ranges which are specified in paragraph 7. The switch is continuously rotatable. A detent at each setting insures that the switch will snap into position.

c. ZERO ADJUSTMENT CONTROL. (1) The ZERO ADJ control (R10) is used to set the meter (MI) to zero on the +D C, -D C, or A C range and to midscale when the zero center \pm DC voltmeter is used.

(2) On the OHMS setting of the FUNCTION switch, the ZERO ADJ control will set the meter to zero when a short is placed between the OHMS and COMMON binding posts. The zero setting is made with no input voltage applied and with the d-c probe connected to the COMMON binding posts on the d-c settings and the a-c probe connected to the COMMON binding post on the a-c settings.

d. OHMS ADJUSTMENT CONTROL. The OHM ADJ (R3) control is used to set the meter (MI) to ∞ (infinity) on the resistance scale. This adjustment is made without any resistance being connected between the OHMS and COMMON binding posts.

This control permits the compensation for variations in battery voltage due to the aging of the batteries.

14. Meter

Meter M1 is a specially calibrated milliammeter. It permits the measurement of voltage and resistance. The features of the meter are specified in paragraph 3c(l).

15. Panel Connections

Connections to the binding posts are made with the test leads supplied. The binding posts have rectangular slots which will accept the tip jacks of the test leads. The test lead is held in place by turning the cap clockwise. Use only enough torque to keep the test lead from slipping out of place. Too much torque will strip the threads or clamp down so hard that it will not be possible to open the binding post.

a. CASE BINDING POST. The CASE binding post is electrically connected to both the case and chassis of the multimeter. Before placing the multimeter in operation, connect the CASE binding post to a good ground.

b. COMMON BINDING POST. The COMMON binding post is used in conjunction with the d-c probe, OHMS binding post, or a-c probe at frequencies lower than .5 mc/s. Refer to paragraph 18a(2) for a discussion of voltage measurements above .5 mc/s.

(1) To measure d-c voltage, connect the tip jack of a test lead to the COMMON binding post. Connect the other end of the test lead and the d.-c probe to the unknown voltage.

(2) To measure a-c voltage, connect the tip jack of a test lead to the COMMON binding post. Connect the other end of the test lead and the a-c probe to the unknown voltage.

(3) To measure resistance, insert test leads into the OHMS and COMMON binding posts and connect these leads to the unknown resistor.

c. OHMS BINDING POST. The OHMS binding post is used in conjunction with the COMMON binding post to measure resistance.

Section III. OPERATION UNDER USUAL CONDITIONS

16. Preliminary Starting Procedure

Before using Electronic Multimeter TS-505/U, carefully read the instructions covering its use. *Obey all cautions.* The adjustments outlined below constitute the adjustments necessary to permit the multimeter to function efficiently.

- a. Remove the front cover of the multimeter by opening the four catches (see caution, par. 9c).
- b. Check the voltage and the frequency of the power source into which Electronic Multimeter TS-505/U will be plugged. The voltage must be between 100 and 130 volts and the frequency must be between 50 to 1,600 cycles. If the voltage and the power source are correct, remove the line cord from the compartment and plug it into the a-c socket.
- c. See that the FUNCTION switch (S1) is in the OFF position. Operate the switch clockwise to any desired position. The pilot light on the front panel should glow.
- d. Allow the multimeter to warm up for at least 3 minutes.
- e. The test leads may be connected while the multimeter is warming up. Remove a set of test leads from the front cover and connect them to binding post OHMS and COMMON. Set the FUNCTION switch to the + D C volts position.
- f. While the multimeter is warming up, the indicator pointer will drift rapidly. This is normal. When the indicator pointer has stopped drifting, it will probably be near, but not at, zero volts. To adjust the indicator pointer to zero, connect the d-c probe to the COMMON terminal, place the RANGE switch at the 2V position, and then rotate the ZERO ADJ control.
- g. Turn the FUNCTION switch to the \pm D C position. The pointer on the meter should be at midscale within plus or minus one division. If the pointer is within these limits, set it to midscale by rotating the ZERO ADJ control. Make this adjustment with the d-c probe connected to the COMMON terminal and with the RANGE switch in the 2V position. If the meter pointer is not within the stated limits, refer to paragraph 52b through j for corrective measures.
- h. Turn the FUNCTION switch to the -D C position. The meter pointer should read zero. If it does not, refer to paragraph 48 for adjustment.
- i. Turn the FUNCTION switch to the OHMS position. Operate the RANGE switch to any resistance range. The indicator pointer should deflect to full scale.
 - (1) If no deflection is obtained, see that the batteries are in place. The batteries are located under the battery cover on the front panel. To remove the battery cover, unscrew the six screws holding the cover in position. Observe polarity when inserting the batteries (par. 19c). If the indicator pointer deflects in a negative direction while the FUNCTION switch is set in the OHMS position, the batteries are probably reversed.

(2) Rotate the OHM ADJ control (R3) to set the meter to read full scale (oo). Connect the two leads from terminals OHMS and COMMON together. The meter pointer should now indicate zero. If the meter pointer does not indicate zero on the scale, reset it by operating the ZERO ADJ control. Recheck oo setting; readjust to this setting, if necessary, by operating OHM ADJ control.

Note. Electronic Multimeter TS-505/U is shipped without batteries. Batteries must be ordered through regular supply channels.

j. Turn the FUNCTION switch to the A C position. The indicator pointer should read to within one division of zero. This reading should be made with the a-c probe connected to the COMMON terminal. If the meter pointer is not within the above limits, refer to paragraph 52m through p for corrective measures.

k. The meter has now been adjusted and measurements may be made with it.

17. Measuring and Reading D-c Voltages

a. MEASURING D-C VOLTAGES. (1) To measure d-c voltage, set the FUNCTION switch to an appropriate d-c position, select the proper range with the RANGE switch, and connect the d-c probe and a test lead from the COMMON binding post to the unknown voltage.

(2) Connect the common lead to the unknown voltage at the end nearest to ground potential. If the magnitude of the voltage under test is not known, operate the RANGE switch to the 1000V position. Turn the switch counterclockwise, one step at a time, until the largest on-scale deflection of the meter pointer is obtained.

(3) If the meter pointer deflects below zero, turn the FUNCTION switch to -D C position if it was previously at +D C and to +D C position if it was previously at -D C.

(4) The FUNCTION switch may be set to \pm D C position to determine whether the voltage under measurement is positive or negative. When that is determined, it may be set to the appropriate polarity. Note that the maximum voltage that can be measured on the \pm D C scale is 500 volts.

b. READING D-C VOLTAGES. Both positive and negative d-c voltages are read on the largest arc on the meter (fig. 3). The zero center scale is read on the third arc from the top. Note that voltages to the right of zero center are positive voltages while those to the left of zero center are negative voltages. The maximum voltage that can be measured on the zero center scale is 500 volts.

18. Measuring and Reading A-c Voltages

a. MEASURING A-C VOLTAGES. (1) To measure a-c voltages, remove the a-c probe from its compartment and attach the tip of the probe to the circuit under measurement. Turn the RANGE switch to the appropriate voltage position. Turn the FUNCTION switch to position A C. Connect a test lead from the COMMON binding post to the low potential side of the unknown voltage.

(2) When high-frequency voltage measurement is to be made (above .5 mc/s), use the shell of the a-c probe in place of the connection to the COMMON binding post. Keep the connection to the shell short especially when the frequency approaches and exceeds 10 mc/s. At frequencies over 50 mc/s, make the connection to the shell of the probe so that it contacts as much of the shell as possible near the tip end of the a-c probe.

Caution: The maximum allowable input to the a-c probe is 200 volts rms. Excess voltage may puncture the input capacitor (C1).

b. READING A-C VOLTAGES. All a-c voltages except those in the 0- to 2-volt range are read on the same scale as the d-c voltages (outer arc). When the RANGE switch is operated to the 2V position, the voltages are read on the 0 to 2.0 ACV scale (bottom arc) (fig. 3).

Note. The meter is calibrated to read the rms value of a sine wave or .707 of the peak voltage of a complex wave.

19. Measuring and Reading Resistance, and Adjusting Ohms Scale

a. MEASURING RESISTANCE. (1) To measure resistance, turn FUNCTION switch to the OHMS position. Connect test leads to the OHMS and COMMON binding posts. Adjust for the maximum scale reading (co) of the ohmmeter by rotating the OHM ADJ control. Short the test leads and rotate the ZERO ADJ control until the meter pointer is in the zero position. This adjustment compensates for the resistance of the test leads. The test leads can now be disconnected and the full-scale reading readjusted if necessary.

(2) Connect the unknown resistor across the test leads and read the resistance measurement on the meter.

(3) In making resistance measurements of components which are not connected directly to ground, connect the test lead from the COMMON binding post to the end of the unknown resistance which is closest to ground. For example, in measuring the plate load resistor of an amplifier, connect the COMMON binding-post test lead to the end nearest B+ and the OHMS binding-post test lead to the end nearest the plate.

b. READING RESISTANCE. Resistance is read on the second arc from the top of the meter.

The resistance is determined by both the position of the RANGE switch and the meter reading. For example, if the meter reading is 30 and the RANGE switch is set at RX10K, the resistance is 30 times 10,000, or 300,000 ohms.

c. ADJUSTING FOR FULL DEFLECTION. (1) If it is not possible to get the meter to read oo with the OHM ADJ control fully clockwise, it will be necessary to replace the batteries.

(2) To replace the batteries, remove the six screws (fig. 3) which hold the battery cover to the chassis. Remove the batteries and replace them with fresh ones. Be sure that the polarity is correct. The positive contact (+) at the bottom of the battery holder should contact the positive battery terminal of one battery. The negative contact (-) at the bottom of the other battery holder should contact the case of the other battery. With the batteries in place, replace the battery cover. Be sure that the rubber gasket is in place. Fasten the battery cover by tightening the six screws.

20. Stopping Procedure

- a. Rotate the RANGE switch to the 1000V position.
- b. Rotate the FUNCTION switch to the extreme counterclockwise position (OFF).
- c. Remove the a-c plug from the power source.
- d. If no immediate use for the meter is contemplated, put the test leads on the cover, replace the a-c probe, d-c probe, and a-c line cord in their respective compartments. Replace the front cover and close the catches. Cover the multimeter to protect the meter and to prevent a carelessly dropped tool from breaking the instrument.

21. Purpose and Use of Equipment Performance Checklist

a. GENERAL. The equipment performance checklist (par. 22) will help the operator to determine whether Electronic Multimeter TS-505/U is functioning properly. The checklist gives the item to be checked, the action or condition under which it is to be checked, the normal indications of correct operation, and the corrective measures. The checklist describes the operations which may be performed by the operator.

b. ACTION OR CONDITION. For some items, the information given in the *Action or condition* column consists of setting various switches and controls under which the items are checked. For other items, it represents an action that must be taken to secure a given condition in order to check the normal indication given in the *Normal indication column*.

c. NORMAL INDICATION. The normal indications listed include the visible signs that the operator should find when he checks the items.

In meter readings, the meter indications are given. Apply the recommended corrective measures if the indications are not normal.

d. CORRECTIVE MEASURES. When normal indications are not present, the operator may perform the corrective measures listed without turning in the equipment for repairs. If the multimeter is completely inoperative or if the recommended corrective measures do not yield results, turn over the equipment to a repairman as soon as possible. *Trouble-shooting and repair should be performed only by qualified repair personnel.* If the situation requires that service be maintained and the multimeter is not entirely inoperative, keep it in operation as long as possible.

22. Equipment Performance Checklist

Item No.	Switch setting		Action or condition	Normal indication	Corrective measure
	FUNCTION	RANGE			
1	OFF.	Any.	Proper position of meter pointer with no power applied to instruments.	Pointer should be within $\frac{1}{2}$ division of zero on meter.	Replace meter (M1) and return defective meter for repair.
2	+D C.	Any.	Plug into a-c socket and turn instrument on.	Pilot light should glow.	Check pilot lamp. See instructions in paragraph 42a for removing back cover.
3	+D C.	Any.	Warm up.	Meter should deflect rapidly and gradually settle to zero.	See paragraph 52b through f.
4	+D C.	2V.	Set meter pointer to zero with d-c probe connected to COMMON.	Rotation of ZERO ADJ should set pointer to zero.	See paragraph 52b through f.
5	+D C. -D C. ±D C.	Depends on applied voltage.	Apply d-c voltage to d-c probe.	Meter should indicate voltage.	See paragraph 52r.

22. Equipment Performance Checklist

Item No.	Switch setting		Action or condition	Normal indication	Corrective measure
	FUNCTION	RANGE			
6	A C.	2V.	Set meter pointer to zero with a-c probe connected to COMMON.	Rotation of ZERO ADJ should set pointer to zero.	See paragraph 52m through p.
7	A C.	Depends on applied voltage.	Apply a-c voltage to a-c probe.	Meter should indicate voltage.	See paragraph 52u through z.
8	OHMS	Depends on resistor selected.	Connect resistor to OHMS and COMMON.	Meter should indicate resistance of resistor.	See paragraph 52t.
9	OFF	Any.	Turn meter off.	Pilot light goes out.	Replace defective snap switch.

Section IV. OPERATION UNDER UNUSUAL CONDITIONS

23. General

Electronic Multimeter TS-505/U is made to operate under all unusual conditions, such as extreme heat, cold, humidity, or sand conditions, without utilizing any special precautionary measures. However, the dry batteries (BA-30) used with this equipment will fail under conditions of extreme cold.

24. Batteries

If special low-temperature batteries are substituted for the BA-30, no special measures whatsoever need be taken. If type BA-30 batteries are used, they must be protected against the cold by preheating, and must be placed in a bag lined with kapok, animal skins, or woolen clothing to prevent heat loss.

CHAPTER 3

MAINTENANCE INSTRUCTIONS

Section I. LUBRICATION AND PRESERVATION

25. Lubrication

No lubrication is required on Electric Multimeter TS-505/U. The rotating parts are so constructed that further lubrication is unnecessary.

26. Weatherproofing

Electronic Multimeter TS-505/U is completely sealed and is impervious to all foreign matter. The multimeter therefore requires no special weatherproofing maintenance. For further information, refer to paragraph 23 and the note at the end of paragraph 31.

27. Rustproofing and Painting

a. Whenever the finish on the case and cover has been badly scarred or damaged, touch up the bared surface to prevent rust and corrosion. Clean the scarred surface down to the bare metal. Use #000 sandpaper to obtain a bright, smooth finish. For severe rust, use Solvent, dry-cleaning (SD) to soften the rust and then use sandpaper to remove the rust.

Caution: Do not use steel wool or emery cloth instead of sandpaper. Minute particles of conducting material may enter the cabinet and cause shorting or grounding of circuits.

b. Before repainting, touch up bared metal parts with a primer coat and allow them to dry. When a touch-up is needed, apply paint with a small brush. Do not remove any electrical parts to accomplish the painting. Paint used will be authorized and consistent with existing regulations.

Section II. PREVENTIVE MAINTENANCE SERVICES

28. Definition and Importance of Preventive Maintenance

a. **DEFINITION.** Preventive maintenance is work performed on equipment (usually when the equipment is not in use) to keep it in good working order so that break-downs and needless interruptions in service will be kept to a minimum. Preventive maintenance differs from trouble shooting and repair since its object is to prevent breakdowns and the resulting need for trouble shooting and repair.

b. **IMPORTANCE.** Since the failure or inefficient operation of even one item may cause the break-down of an entire system, the importance of preventive maintenance is at once apparent. Operators must maintain equipment placed in their charge in such condition that it will work at top efficiency at all times.

29. General Preventive Maintenance Techniques

a. Use #0000 sandpaper to remove corrosion.

b. Use a clean, dry, lint-free cloth or a dry brush for cleaning.

(1) If necessary, except for electrical contacts, moisten the cloth or brush with solvent (SD); then wipe the parts dry with a cloth.

(2) Clean electrical contacts with a cloth moistened with carbon tetrachloride; then wipe them dry with a dry cloth.

c. For further information on general preventive maintenance techniques, refer to TB SIG 123.

30. Specific Preventive Maintenance Techniques

The electrical components of Electronic Multimeter TS-505/U require routine preventive maintenance to keep the instrument operating at peak efficiency. Hit-and-miss methods are not satisfactory. For this reason, only authorized preventive maintenance should be practiced, and the instructions given here are to be used as a guide for personnel assigned to such service.

Caution: Do not tighten screws, nuts, and bolts beyond the pressure for which they are designed. Overtightening will result in bent, broken, or otherwise damaged parts and stripped threads.

a. When possible, perform all work with the instrument disconnected from the power line and any other equipment.

b. Check for overheating of components. If any component, other than the tubes, becomes so hot that it cannot be touched, the temperature is too high and the cause should be investigated.

c. Visual inspection is the most important operation in preventive maintenance because it may be the first indication that repairs or adjustments are required.

A careful observer will not overlook minor signs of trouble since valuable time and effort will be saved if they are corrected before a major break-down occurs. A maintenance man should be thoroughly familiar with the normal operations of the instrument to be able to recognize signs of a defective instrument.

(1) Carefully examine all parts of the equipment, noting state of cleanliness, placement of wires, and any signs of overheating as indicated by discoloration of the affected part. Note the general condition of resistors, capacitors, switches, and wiring.

(2) Look for loose or broken connections, loose mountings or parts, and cut, frayed, or peeling insulation on wiring.

(3) Examine all recesses for accumulation of dust or dirt especially between connecting terminals. Keep parts, connections, and terminals free of dirt and corrosion. In tropical and high humidity locations, look for fungus growth and mildew.

(4) Examine all tubes to see that they are seated properly in their sockets and check all mounting screws and nuts to see that they are tight. Whenever a loose connection is tightened, it should be moistureproofed and fungiproofed by applying varnish with a small brush.

31. Preventive Maintenance Checklist

The following checklist is a summary of the preventive maintenance operations to be performed on Electronic Multimeter TS-505/U. For best performance of the instrument, follow the procedure specified in the checklist at least as frequently as called for. Preventive maintenance should be done in accordance with the techniques detailed in paragraph 30. Do not use gasoline as a cleaning fluid; do not smoke near inflammable liquids.

Note. Because the multimeter is of sealed construction and is impervious to the entry of dirt, dust, etc., limit all routine preventive maintenance to items which do not require removal of the panel and chassis assembly from the case. Design of the unit is such that disassembly should be attempted only when performance is definitely faulty or where specified.

31. Preventive Maintenance Checklist (cont)

Item No.	What to check	When to check	How to check	Precautions
1	FUNCTION switch.	Daily.	Set switch to each position. Wobble switch and see whether the indicator pointer returns to position. If action is not positive, send multimeter to depot for repair.	
2	ZERO ADJ and OHM ADJ.	Daily.	Rotate slowly and evenly. Watch indicator pointer for uneven movement which indicates dirt or wear. Send multimeter to depot for repair.	
3	RANGE switch.	Daily.	Check action of switch by rotating slowly and evenly. See that switch snaps into detents.	
4	Knobs.	Daily.	Check for looseness on shaft; tighten set screws.	
5	Test leads.	Daily.	Inspect visually for breaks and worn spots.	
6	A-c line cord.	Daily.	Inspect visually for breaks and worn spots.	
7	Binding posts OHMS, COMMON, CASE.	Monthly.	Gently grip base of binding post between fingers and try to rotate. If it rotates tighten nut inside.	Do not strip threads; do not break insulators.
8	D-c probe.	Monthly.	Apply voltage to cable (connect to OHMS binding post) and gently pull wire; meter pointer should not fluctuate. If it does, send multimeter to depot for repair.	

31. Preventive Maintenance Checklist (cont)

Item No.	What to check	When to check	How to check	Precautions
9	Test leads.	Monthly.	Connect between OHMS binding post and COMMON binding post and gently pull wire; if meter pointer does not remain at zero, check for open wire or poor contact between wire and test prod or tip jack.	
10	Meter.	Monthly.	Apply voltage to d-c probe (touch to OHMS binding post) and suddenly remove d-c probe. Meter pointed should return to zero smoothly and without sticking. If meter sticks, send multimeter to depot for repair.	Meter should be at zero with no applied voltage.
11	A-c probe cable.	Monthly.	Apply a-c voltage to probe and twist cable slightly. If meter pointer fluctuates, send multimeter to depot for repair.	
12	A-c line cord and plug.	Monthly.	Wiggle plug in socket and gently tug wire while holding plug in socket. Pilot light should not flicker. If it does, clean blades of plug with #0000 sandpaper; tighten screws which hold the wire; tighten cable clamps.	When making these tests make sure that the socket into which cable is plugged is not at fault.
13	Nuts and screws.	Monthly.	Tighten screws (on exterior) with screw driver.	Do not strip threads.

31. Preventive Maintenance Checklist (cont)

Item No.	What to check	When to check	How to check	Precautions
14	Case and cover.	Monthly.	Clean away all dust and corrosion. Use brush and solvent (SD). Repaint scratched areas.	
15	Tubes.	Semi-annually.	Check for quality on tube tester. Check for gas current (par. 48). Replace if necessary.	
16	Sockets.	Semi-annually.	Clean off dust. Rock tubes back and forth slightly and note whether meter pointer fluctuates. If it does, check for poor contact on tube pins. Tighten socket contacts or return to depot.	High voltage exists inside meter. Clean sockets with instrument disconnected. Use only one hand when wiggling tube.
17	Transformer.	Semi-annually.	Tighten mounting nuts.	Do not strip threads.
18	Capacitors.	Annually.	Clean off dust from terminals. Look for oil leaks on C8 and C9. If oil is found, return to depot for replacement. Look for broken case or leads on other capacitors. If these are found, return to depot for replacement.	

Note: Wherever the continuity of the moistureproofing and fungiproofing has been destroyed, restore it by applying a new coating with a small brush.

CHAPTER 4
FIELD MAINTENANCE INSTRUCTIONS

Section I. THEORY OF OPERATION

32. Scope and Application

This chapter contains information for field maintenance applicable to all phases of repair. It outlines the repair procedures necessary to recondition the equipment, the methods of locating and clearing troubles which are disclosed, and the method of calibrating the multimeter. The amount of repair to be performed by any particular unit having field or depot maintenance responsibilities is limited, in these instructions, only by two things: the tools and test equipment available and the skill of the assigned personnel.

33. Block Diagram

The block diagram (fig. 5) illustrates the main circuit components of the multimeter. They are: a power supply, an a-c probe, a d- probe, a switch section, an amplifier, and an indicating meter.

a. **POWER SUPPLY.** The power supply furnishes the necessary operating potentials to the amplifier portion of the instrument. Two 1 1/2-volt dry cells (BA-30) are included as part of the power supply. These dry cells supply voltage to the ohmmeter circuit.

b. **AMPLIFIER.** The amplifier receives the input voltage at a high impedance and converts it to the same voltage at a low impedance. This output voltage is then applied to the indicating meter.

c. **INDICATING METER.** The indicating meter is a 0- to 1-ma movement with the appropriate scales (fig. 3) printed on the face.

d. **D-C PROBE.** The d-c probe is a test prod with a built-in isolating resistor to prevent capacitive loading of the circuit under measurement.

e. **A-C PROBE.** The a-c probe (figs. 11, 20, and 21) consists of a diode mounted in a holder. In addition, there is a coupling capacitor, a coupling resistor, and bypass capacitors. The diode acts as a rectifier which changes the applied ac to dc. The dc is then applied to the amplifier and indicated on the meter.

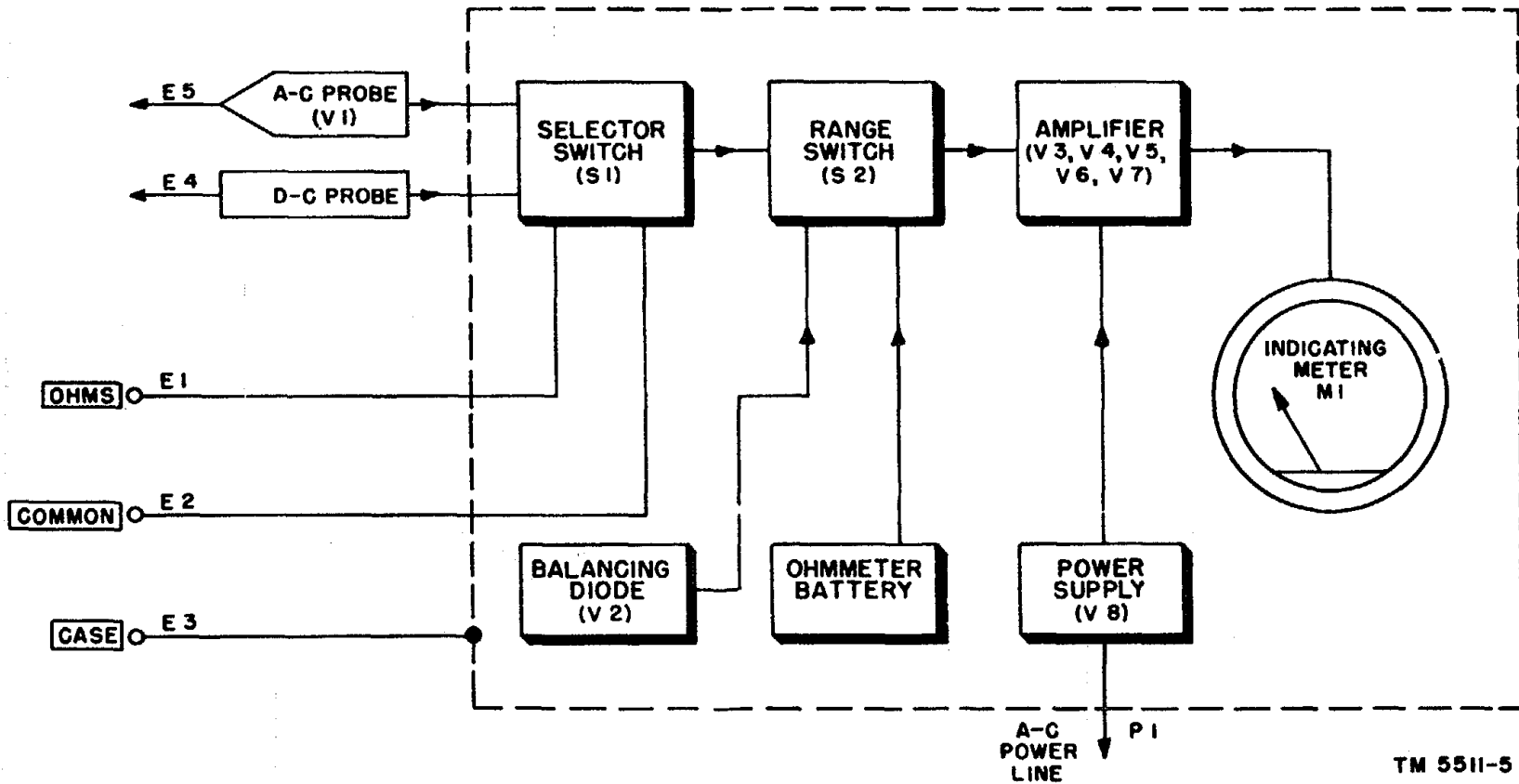

Figure 5. Electronic Multimeter TS-505/U, block diagram.

Because of its construction, the input resistance is high (in excess of 6 megohms) over the audio range, and the input capacity is low (2 uuf). The a-c probe can be used from 30 cps to 500 mc/s.

f. SWITCH SECTION. (1) The RANGE switch (S2) is used to select the proper range on voltage or resistance measurements.

(2) The FUNCTION switch (S1) is used to select the desired function. In the extreme counterclockwise position (OFF), the switch turns the instrument off.

g. TERMINALS. (1) The OHMS and COMMON terminals are used in the measurement of resistance.

(2) The CASE terminal is a connection to the cover and chassis of the multimeter. It permits grounding the instrument so that the influence of external fields is negligible.

34. Power Supply

a. Figure 6 is a simplified schematic diagram of the power supply. It includes a conventional full-wave rectifier using a 6X4 tube (V8) to supply 310 volts at 12 ma for the amplifier plate supply. The power supply is designed to operate over a frequency range of 50 to 1,600 cps and takes approximately 20 va at 115 volts.

b. The power transformer (T1) steps up the line voltage (115 volts nominal) to 500 volts. This voltage is applied to the plates of tube V8. Transformer T1 also steps down the line voltage to 6.3 volts for the heaters of the tubes and for the pilot light (E13). The function of the electrostatic shield is to bypass power line hash to ground so -that the operation of the meter is not affected.

c. The output of the rectifier (VS) is filtered by C8, C9, and R42. Note that this supply differs from conventional power supplies in that the center tap of the high-voltage winding is not connected to the common bus. With respect to the common bus, the positive voltage is 165 volts dc and the center tap of T1 is - 103 volts dc.

d. Fuses F1 and F2 are placed in the primary of transformer T1 to prevent damage to the transformer in the event that abnormal currents are required from it. These fuses are rated at 1 ampere.

e. Switch S1, section 7, is a DPST (double-pole, single-throw) snap switch. It is used to turn the instrument on or off. It is part of switch S1 and is actuated when S1 is rotated clockwise to turn the instrument on.

f. Pilot light E13 indicates whether the instrument is on. The light is filtered through a colored lens.

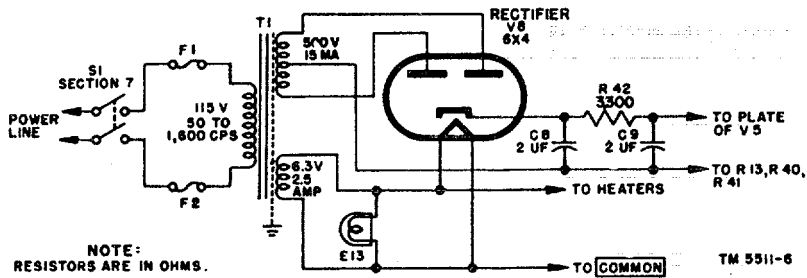

Figure 6. Power supply, simplified schematic diagram.

35. Amplifier

a. The amplifier portion of the multimeter consists of tubes V3, V4, V5, V6, and V7. The operation of the amplifier will be understood more easily after an analysis of the circuit in figure 7. If the coupling batteries are removed, the screen grid, plate, and cathode of one tube are so phased with the corresponding elements in the other tube that the two tubes will act as a multivibrator. Since the circuit is in a state of oscillation, infinite gain is theoretically available from the amplifier because any minute voltage would be greatly amplified. However, the circuit cannot be used in this manner because it would be much too unstable. If the coupling batteries are replaced, it is seen that the action from plate to grid is degenerative. Under these conditions, the output voltage will be equal to the input voltage, thus maintaining a high input resistance and -at the same time yielding the low output resistance necessary to operate the meter. The magnitude of the voltage from the coupling

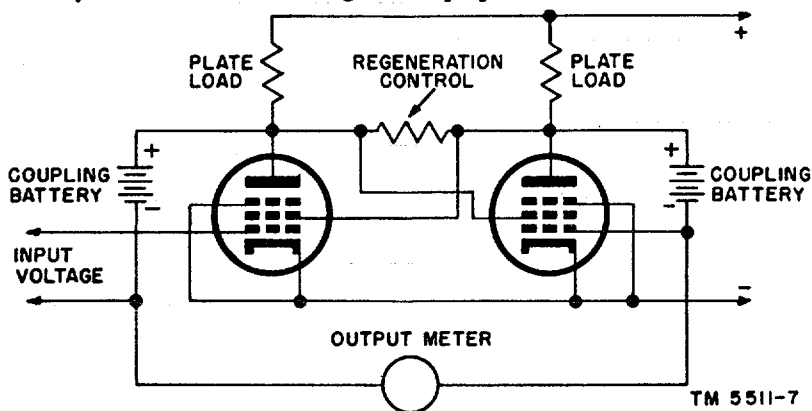

Figure 7. Simplified circuit illustrating amplifier operations.

b. The circuit in figure 8 is a simplified version of the circuit label which is found in Electronic Multimeter TS-505/U. The coupling batteries in figure 7 have been replaced by tubes V5, V6, and V7. Using tube V5 for coupling permits the operation of the plates of tubes V3 and V4 without any loading. Loading would occur if neon glow lamps V6 and V7 were connected directly to the plates of tubes V3 and V4. The neon glow lamps provide a low resistance coupling from tube V5 to the meter. Resistors R9 and R11 determine the gain of tubes V3 and V4. Resistor R12 sets the amplifier gain to unity. Resistors R40 and R41 provide a resistance across which the output voltage is developed. Resistor R13 is the biasing resistor for tubes V3 and V4.

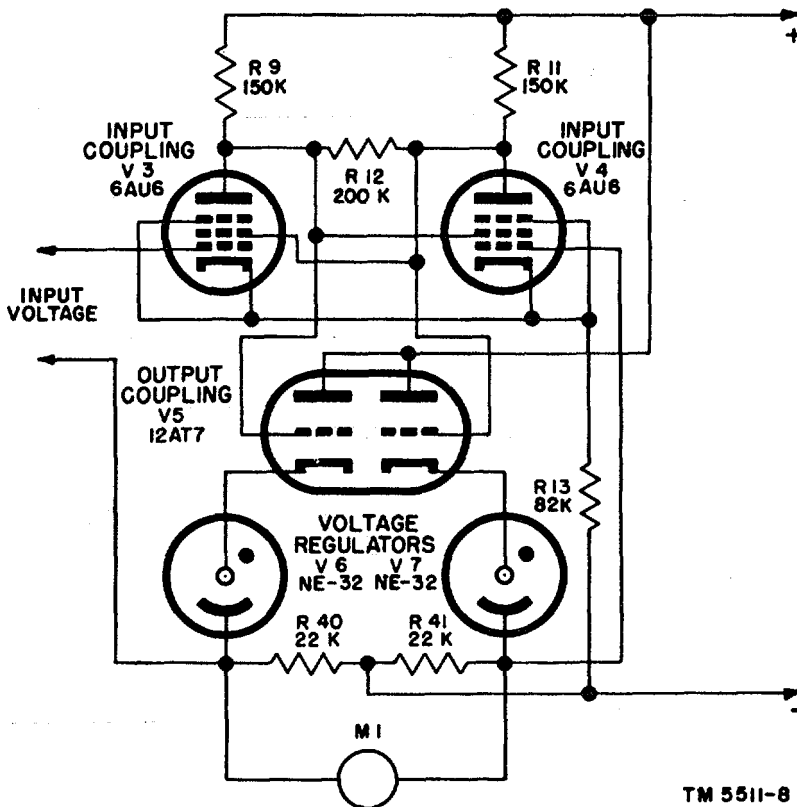

Figure 8. Amplifier, simplified schematic.

c. The actual schematic diagram of the amplifier in the multimeter (fig. 9) is the same as that in figure 8 with the addition of several components.

Resistor R10 is used to adjust the zero setting of the meter. Resistor R14 is a coarse zero adjustment to allow for large variations in the characteristics of tubes V3 and V4 and to set the multimeter within the range of resistor R10. Note that the negative point of the power supply is not connected directly to one terminal of the input voltage under measurement. In figures 7, 8, and 9, the schematic indicates an open circuit in the grid of V3; actually, a resistor appears across this grid at all times. In figure 9, the indicating meter is not shown because the output is first applied to the switch before going to the meter.

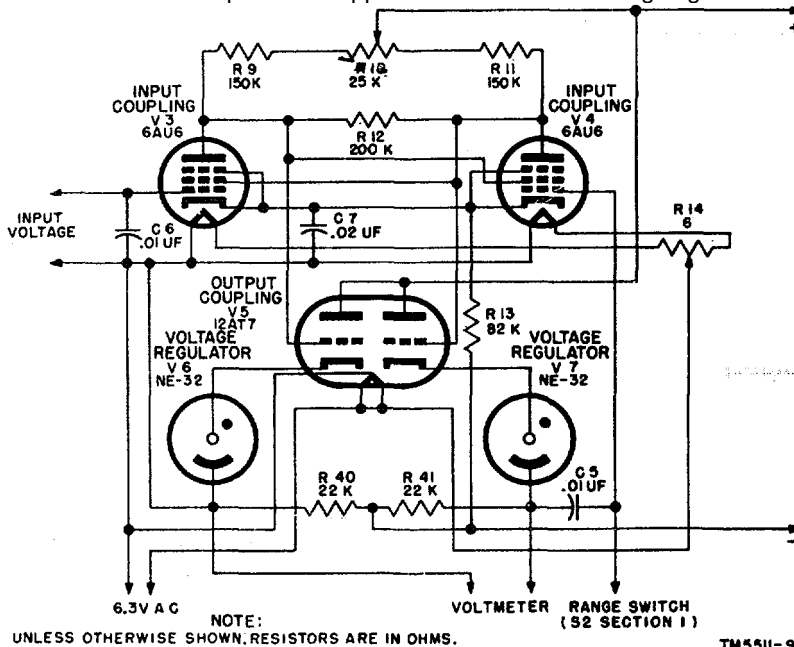

Figure 9. Electronic Multimeter TS-505/U, amplifier schematic .

36. Indicating Meter

The indicating instrument is a 0- to 1-ma basic movement with the appropriate scales printed on the face. Because of the circuit arrangement, the meter will not be damaged if a reasonable overload is placed on the instrument.

37. Switch Section

Figure 10 is a simplified schematic of the switches.

a. FUNCTION SWITCH. The FUNCTION switch turns the multimeter off and also selects the desired function.

In the OHMS position, section 1 of S1 connects the OHMS terminal to the grid of tube V3 (fig. 22); at the other positions, the grid of tube V3 is connected to a resistor of the precision attenuator (R15, R16, R18 through R24) through section 4A of S2. Section 2A of S1 connects the d-c probe to the input of the precision attenuator (R15) at the +D C, $\pm D$ C, or -D C settings and disconnects the attenuator at the OHMS position. At A C, the rectified output of the a-c probe is applied to the input of the precision attenuator through sections 2B and 2A of S1. Section 2 of S1 is broken into two parts to permit resistor R17 to be paralleled with resistor R15 in the 0 to 4 volts a-c position to improve the linearity of the a-c probe. Section 3 of S1 shorts out the contact potential of the balancing diode (V2) at all except the A C setting of the FUNCTION switch. Sections 5 and 6 of S1 connect the proper terminal of the indicating meter to the COMMON terminal. At the OHMS, +D C, and AD C settings, the negative terminal of the meter is connected to the COMMON terminal. At --D C and A C the positive terminal is connected to the COMMON terminal. At the OHMS setting, section 5 of S1 puts resistor R3 in series with resistor R4 to allow for the increased voltage applied to the grid of tube V3 from the batteries. At the A C setting, section 6 of S1 selects resistor R5 instead of resistor R4 to permit a calibration control on the A C ranges. Section 4 of S1 applies .5 ma through meter M1 on the $\pm D$ C ranges so that the meter will read midscale.

b. RANGE SWITCH. The RANGE switch (section 3, 4A, and 4B of S2) performs the function of selecting the appropriate resistor (R15 through R24) for voltage measurements. Section 2 of S2 selects the proper resistors (R32 through R38) for resistance measurements. The resistors (R25 through R31) of section 1 of S2 are used in conjunction with balancing diode (V2) to buck out the contact potential of the a-c probe.

(1) Resistors R15, R16, and R18 through R24 comprise a precision attenuator to select a known fraction of the input voltage before it is applied to the amplifier. Section 3 of S2 shorts out resistor R23 on all ranges except at the 1000V setting so that the sum of resistors R15, R16, R18, R19, R20, R21, R22, and R24 totals 15 megohms. With the 5-megohm resistor (R2) in the d-c probe, the total input resistance is 20 megohms on all d-c ranges except at the 1000V setting. At the 1000V setting, the short circuit across resistor R23 is removed and the input resistance increases to 50 megohms.

(2) The ohmmeter resistors R32 through R38, in conjunction with batteries BA-1 and BA-2, comprise a shunt type ohmmeter. Essentially,

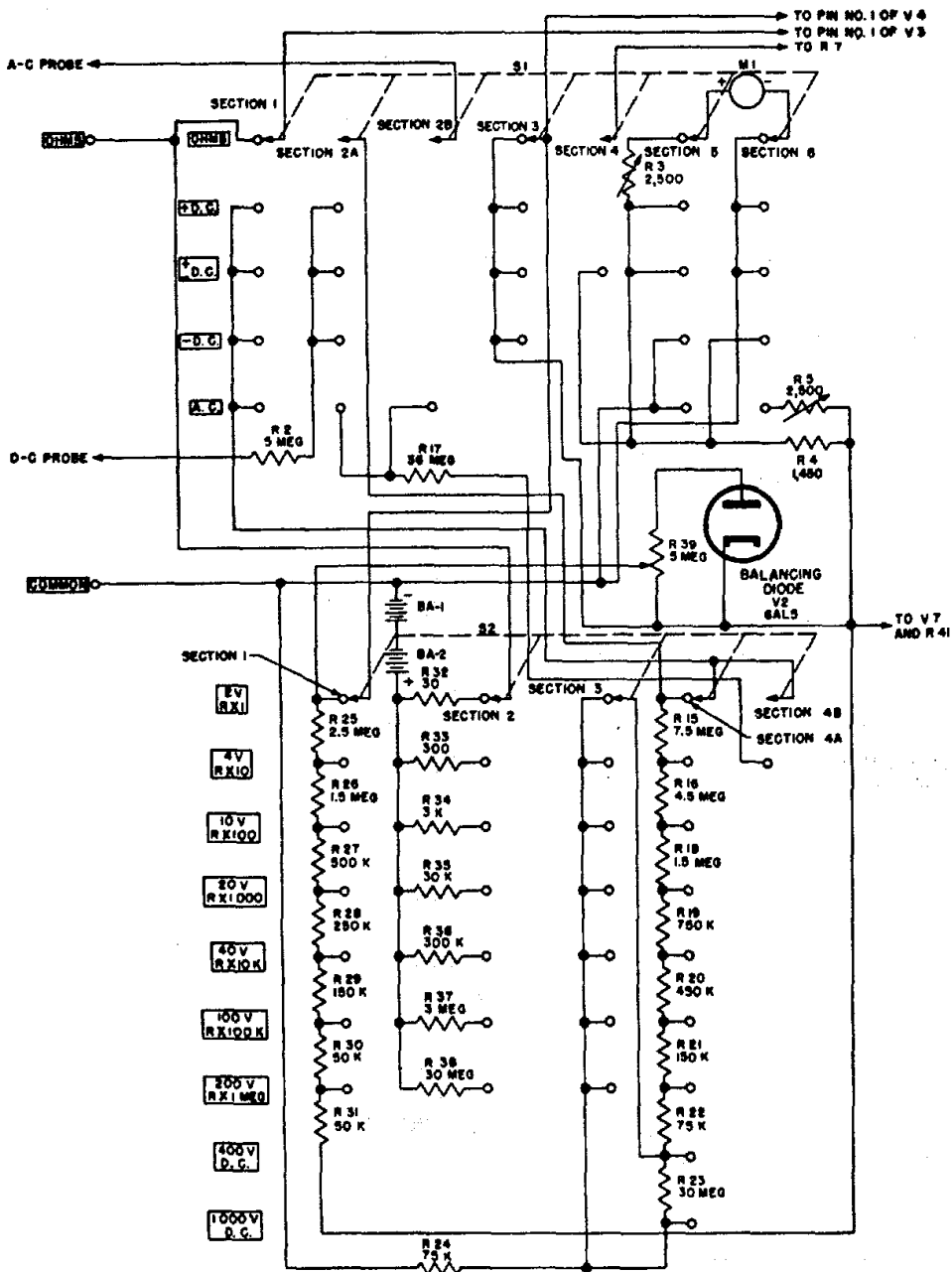

NOTE:
UNLESS OTHERWISE SHOWN, RESISTORS ARE IN OHMS.

TM 5511-10

Figure 10. Multimeter switches, simplified diagram.

the amplifier reads the voltage drop across the unknown resistor placed between OHMS and COMMON. For example, with the RANGE switch set at RX10K and no resistor connected between OHMS and COMMON, the meter is set to read oo with resistor R3, which applies 3 volts to the grid of tube V3. If an unknown resistor of 300,000 ohms is placed between OHMS and COMMON, half the battery voltage will appear across resistor R36 and half will appear across the unknown resistor. This will cause the meter to read midscale which corresponds to 300,000 ohms when the RANGE switch is set at RX10K.

(3) The bank of resistors R25 through R31 is an attenuator for the contact potential of tube V2. A diode such as V1 or V2 will have a d-c output voltage without input voltage applied because of contact potential in the tube. This voltage amounts to about 1/2 to 1 volt depending on the tube type. If the balancing diode V2 were not used, then at the low voltage settings of the RANGE switch a minimum voltage would be applied to the amplifier and would indicate on the meter. Tube V2 in conjunction with resistors R25 through R31 applies an equal voltage to tube V4, thus bucking out this contact potential. Resistor R39 is used to set the bucking potential equal to the contact potential of tube V1. Since the contact potential is a function of the filament voltage, the balancing diode will tend to keep the indicator pointer at zero as the line voltage is varied.

38. D-c Probe

The d-c probe consists of a special test prod containing resistor R2. The placement of resistor R2 at the point of measurement prevents capacitive loading of the voltage under measurement. The tip is of the solderless type designed to accommodate an alligator clip.

39. A-c Probe

a. The a-c probe (figs. 11, 20, and 21) consists of a diode mounted in a special holder to enable the probe to make accurate measurements at high frequencies. The a-c probe (fig. 11) consists of a diode (V1) connected in the circuit as a shunt half-wave rectifier, an input coupling capacitor (C1), an input resistor (R1), and bypass capacitors (C2 and C3). Because of the high value of the input resistor (15 megohms) and the input capacitor (6,000 uuf), the diode is essentially a peak indicating rectifier. The scale of the instrument is calibrated to read rms volts for a sine wave input. For nonsinusoidal input voltages, the instrument reads .707 of the peak value. Diode V2 (6AL5) acts as a balancing diode and is used to buck out the contact potential of V1 with no input applied to the a-c probe (fig. 10).

This balancing is accomplished by rotating resistor R39 until zero deflection on the meter is attained with the probe connected to the COMMON binding post. At high frequencies, it is important to make connections to the voltage under measurement with very short leads. Above 10 mc/s, contact should be made to as much an area as possible near the head end of the probe.

b. As mentioned in subparagraph a above, the diode responds to the peak of the voltage applied for measurement and is calibrated to read the rms value of a sine wave input. If the input wave form is not sinusoidal, the meter will not read correctly, but can be used to determine the peak value of the positive applied input. Therefore, if the input is known to be other than a sine wave, multiply the scale reading by 1.414 to obtain the peak value. For any random phase distribution of harmonic components in the applied wave form, the maximum error will not exceed the sum of the percentages of the harmonics. For example, if the input voltage has a harmonic content of 5 percent, the error in the reading may be anywhere from -5 to +5 percent.

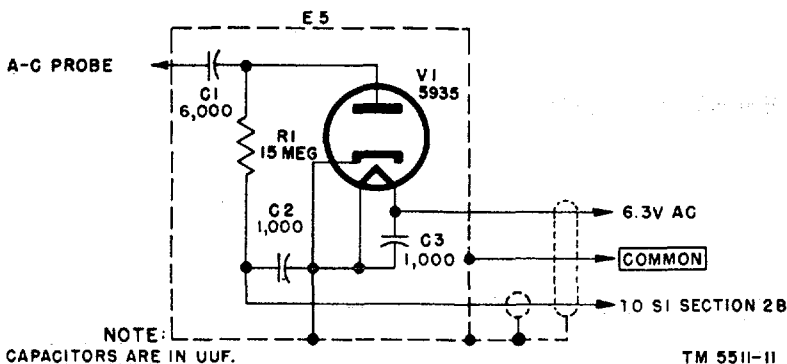

Figure 11. A-c probe, schematic diagram.

Section II. PREREPAIR PROCEDURES

40. Tools, Materials, and Test Equipment

The following tools, materials and test equipment are needed for performing the prerepair procedures listed in this section:

Item	Stock No.
Common hand tools.	
Clean, lint-free cloth.	6Z1989
Sandpaper #0000.	6Z7500-0000
Solvent, dry-cleaning (SD).	6G1914
Small Brush TL-72.	6Z1372
Soldering Iron TL-117.	6R24617
Solder, Rosin Core M-31.	6N7531
Alcohol (for removing excess rosin).	6G16.1
Multimeter TS-352/U, 20,000 ohms per volt.	3F4325-352
Two 1½-volt dry cells (BA-30).	3A-30
Tube Puller TL-201.	6R7442
Tube Tester I-177.	3F5700-177

41. Power Requirements

A power source of 100 to 130 volts, 50 to 1,600 cps must be available. Two dry cells (BA-30) are required to supply voltage to the ohmmeter circuit of the multimeter.

42. Inspection

a. Make a visual inspection of the equipment when it is turned in for repair. To inspect the interior, remove the six screws on the back cover and slide the instrument out of the cover (fig. 12).

Caution: Do not lose the O rubber sealing rings. Get a small box to hold the screws and the O rings.

b. Analyze the extent of the necessary repair and determine whether the condition warrants repair. Two factors must be considered: whether the replacement and repair of major parts justifies the expense involved and the urgency of returning the equipment to service. If there is an urgent need for the equipment and a replacement is not available, the expense involved would be justified. If there is no urgent need and the repair involved would amount to a rebuilding operation with the replacement of many parts, salvage the equipment.

If salvaged, strip the equipment of usable parts and place them in stock for re-use.

c. If there are no visibly defective components, refer to section III for trouble-shooting procedures.

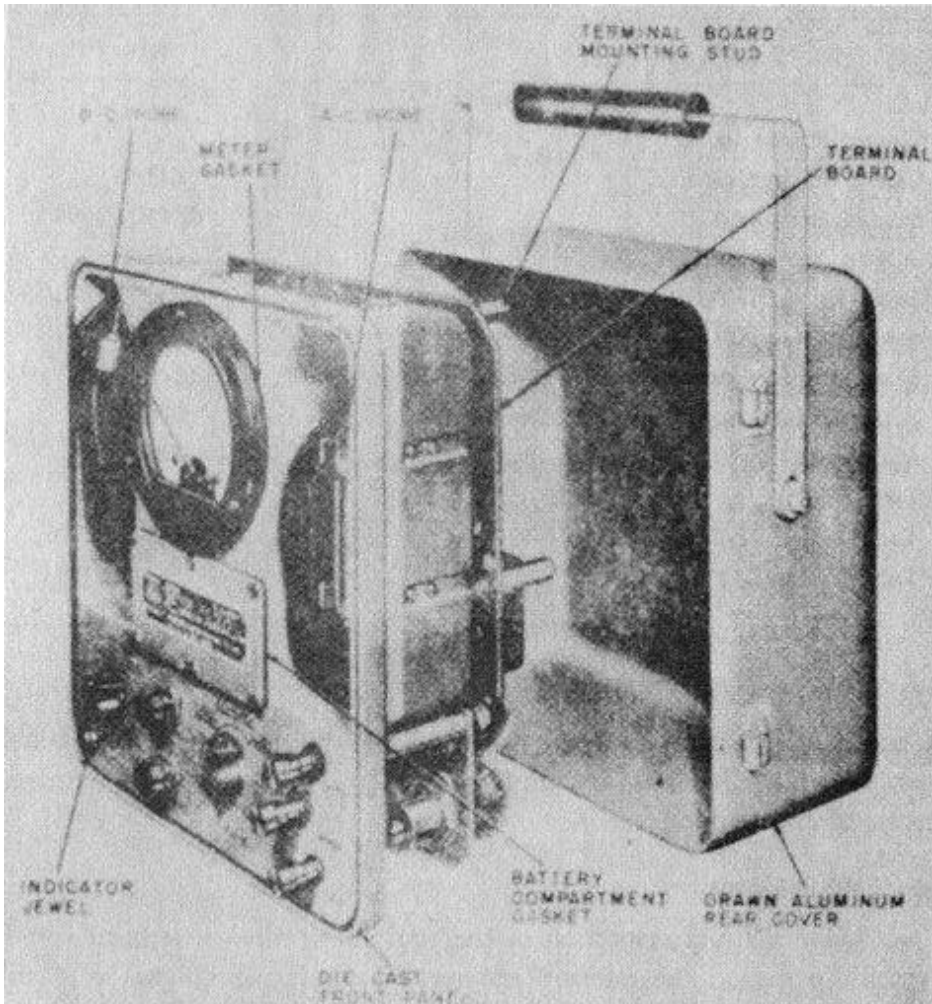

Figure 12. Electronic Multimeter TS-505/U, components removed from case.

43. Removal of Pluck-out Parts

a. Certain parts of the equipment can be removed without unsoldering the various connections. Such parts do not require complicated disconnecting procedures. These are called pluck-out parts; they are the parts that may be inspected easily.

b. Use Tube Puller TL-201 to remove tubes from their sockets. If the tubes are removed with the fingers, make sure that the tubes have cooled sufficiently, then, pull up the tube.

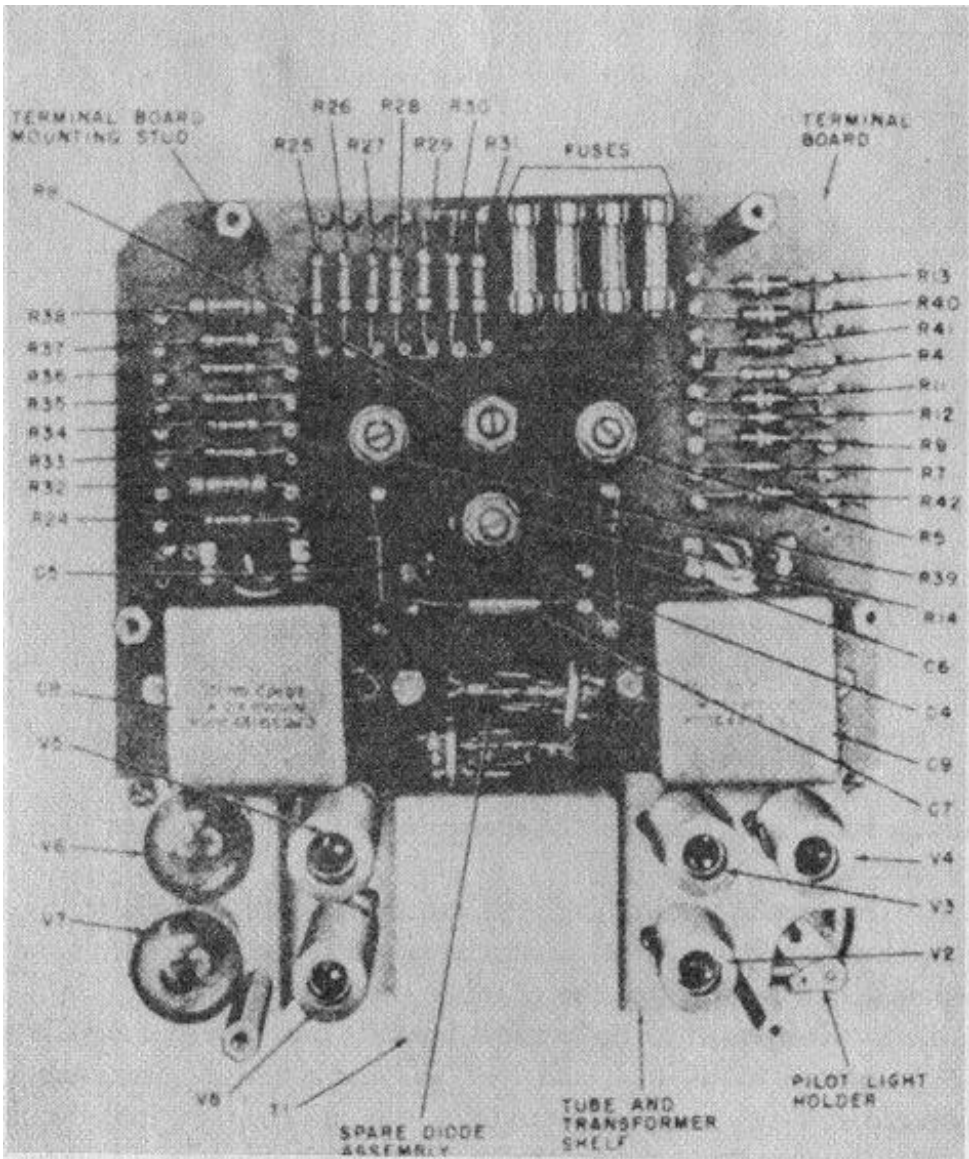

Figure 13. Electronic Multimeter TS-505/U, rear view.

Do not rock the tube or jiggle it in its socket if it can be extracted by a direct upward pull. Rock it *gently* if it does not release easily. Jiggling a tube in its socket during removal spreads the contacts. Label each tube as soon as it is removed so that it can be replaced later in the proper socket. Inspect the tubes for cracks in glass and base and for bent and broken prongs.

44. Stripping

Many of the components of Electronic Multimeter TS-505/U may be salvaged if it is decided that the equipment will not be repaired (figs. 13, 14, and 15).

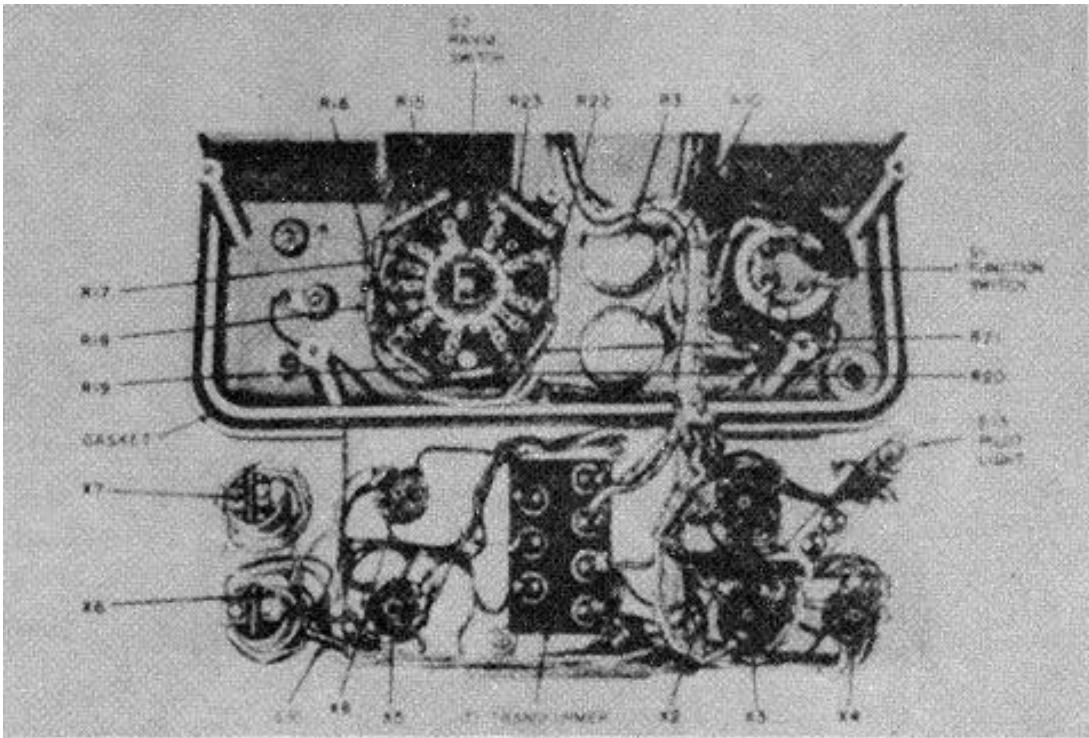

Figure 14. Electronic Multimeter TS-505/U, showing tube and transformer shelf removed.

- a. The terminal board (fig. 13) can be removed by unfastening the four studs which hold it in place. Remove defective components on the terminal board and place the board in stock for re-use.
- b. In the event that the terminal board is broken, capacitors C8 and C9, resistors R5, R8, R14, and R39, and the battery holders should be salvaged if they are in good condition (fig. 15). In general, the fixed resistors mounted on the board are not worth salvaging because the leads would be too short. However, salvage the precision resistors R4 and R24 through R38 even though the leads are short so that some precision resistors are readily available for replacement.
- c. The metal shelf containing the transformer, tubes, tube sockets, pilot light, pilot light socket, and tube shields should be placed in stock if it is in good condition. If the transformer and tube sockets are undamaged, unfasten the shelf (fig. 14) by removing the two screws and the two studs which hold it in place. Place the complete unit, including cables, in stock for future use. If the metal deck is so badly bent that it cannot be salvaged, remove transformer (T1), pilot light, pilot socket, and tube sockets and place them in stock for re-use.
- d. Meter M1, a-c probe, d-c probe, switches S1 and S2, battery cover,

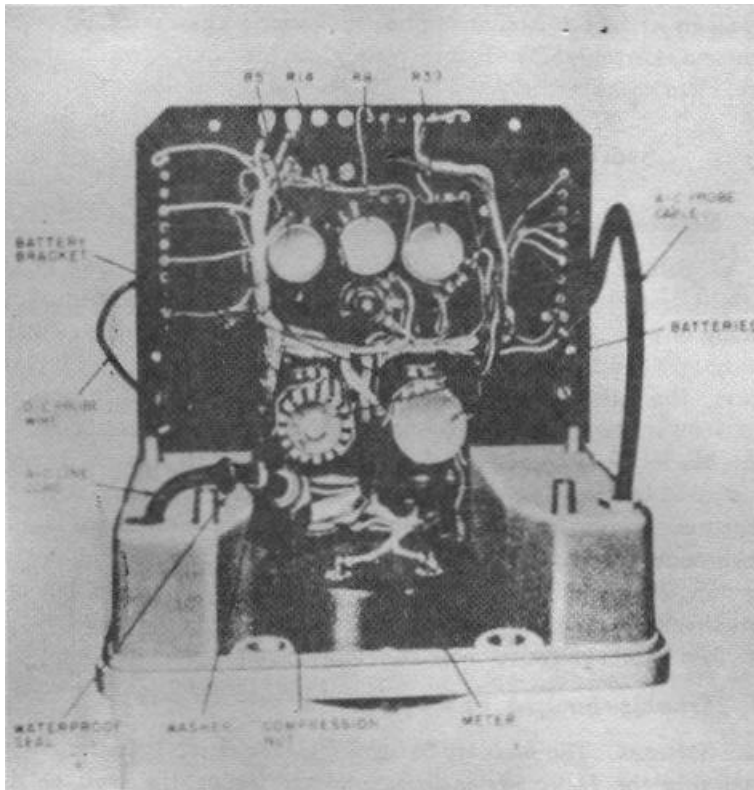

Figure 15. Electronic Multimeter IS-505/U, top view showing under side of terminal board.

line cord and plug, resistors R3 and R10, and binding post E1, E2, and E3 are all located on the front panel. Place these components in stock for re-use if they are in good condition. Be careful not to lose the insulators for the binding posts, the rubber gaskets, and the O rings.

e. The front and rear covers may be placed in stock if they are in good condition. Note that the cables in the unit have enough slack (fig. 15) so that they may be cut close to the soldered end and re-used.

45. Cleaning

If the seal has been broken, thorough cleaning of the multimeter may be necessary to insure optimum performance by preventing corrosion, rust, and dust from damaging parts or causing arc-over or low-resistance leak-

age between high-voltage points and ground. Before starting on repairs, thoroughly clean the interior of the multimeter with a small brush or cloth and solvent (SD). Before placing any salvaged components in stock, clean them carefully.

Section III. TROUBLE LOCATION

46. Preliminary Procedure

a. Before attempting to locate trouble in Multimeter TS-505/U, carefully inspect the equipment to be sure that there is no mechanical binding of switches which might cause damage to the equipment. Rotate switches S1 and S2 to see that they are mechanically sound (no broken decks). The detent action and the stops on switch S1 should be positive (no 3600 rotation). Switch S2 should permit continuous rotation.

b. Make a visual inspection of the equipment for any signs of damage such as loose mounting screws, nuts, bolts, loose or poorly soldered connections, overheated resistors, damaged insulation, and exposed wiring which causes shorts with other wiring, terminals, or ground. The fastening nuts which hold the switches on the front panel and the binding posts should be tight.

c. Use an ohmmeter to check, if a short circuit is indicated.

47. Trouble-shooting Procedures

a. GENERAL. The first step in servicing a defective instrument is to sectionalize the fault. Sectionalization means tracing the fault to the circuit responsible for the abnormal operation of the equipment. The second step is to localize the fault. Localization means tracing the fault to the defective part. Many faults, such as burned-out resistors, tubes, shorted transformers, leaky capacitors, or broken wires can often be located by sight, smell, or hearing. The majority of faults, however, must be localized by checking resistance and voltage.

b. SECTIONALIZATION. Careful observation of the performance of the multimeter on the various ranges may aid in sectionalizing the trouble. Through this inspection alone, the repairman may frequently discover the trouble or determine the circuit in which the trouble exists. For example, if the operation of the multimeter is normal in OHMS, +D C, -D C, and -D C, but refuses to operate on A C, it is evident that the fault lies in the a-c portion of the multimeter. Obviously further attempts at sectionalizing the trouble should be made with the FUNCTION switch in the A C position. Paragraph 22 lists the normal performance of the multimeter switches.

c. LOCALIZATION. After the trouble has been sectionalized, the next step is to locate the specific component, or components, responsible for the improper operation of the multimeter. In the example cited in subparagraph b above, the fault might lie in a defective FUNCTION switch, a nonfunctioning a-c probe, broken a-c probe cable, or some similar portion of the equipment. Refer to the theory of operation (pars. 32 through 39), the schematic diagram (fig. 22), the trouble-shooting chart (par. 50), and the resistance and voltage charts (figs. 16 and 17) for information which will aid in the location of the source of trouble.

48. Gas Checks

a. The proper operation and performance of the multimeter is dependent upon a set of tubes which are capable of satisfactory performance. Small variations in tube characteristics are overcome by resistor R14, provided that the tubes are not gassy. Thus, it is necessary to check for gas in the tubes. Tubes V3 and V4 are affected most critically by gas within their envelopes.

b. Check for gas by performing the following procedure:

(1) Plug the multimeter into the power line socket (100 to 130 volts, 50 to 1,600 cps). Turn the FUNCTION switch to +D C position and allow the multimeter to warm up for about 10 or 15 minutes.

(2) Set ZERO ADJ resistor R10 to its mechanical center. Connect d-c probe to COMMON binding post. Set RANGE switch to 2V position.

(3) Loosen locknut on resistor R14.

(4) Rotate resistor R14 until the indicator pointer is within $\frac{1}{2}$ division of the zero position. Wait approximately 1 minute between settings since the action of this control is sluggish.

(5) Tighten the locknut on resistor R14; be careful not to disturb the setting of the meter pointer and the setting of the control.

(6) Set the meter needle to zero position with ZERO ADJ resistor.

(7) Place a short circuit across capacitor C6. The shift of the meter needle should be less than 1 division.

(8) If the shift is greater than 1 division, allow the multimeter to operate for several hours. Then repeat the steps of subparagraphs 1 through 7 above. If the shift is still greater than 1 division, replace tubes V3 and V4. Check the replacements by performing the steps of subparagraphs 1 through 7 above.

49. General Precautions

Whenever the multimeter is serviced, observe the following precautions carefully:

a. Before unsoldering a part, note the position of the leads. If the

part, such as a transformer, has a number of connections, tag each of the leads to it. Whenever possible, tag each lead of every part removed. The multimeter may then be accurately rewired using the schematic diagram.

b. Be careful not to damage other leads by pulling or pushing them out of the way.

c. Do not allow drops of solder to fall into the multimeter, since they may cause short circuits.

d. A carelessly soldered connection may create a new fault. It is very important to make well-soldered joints because a poorly soldered joint is one of the most difficult faults to find. Use alcohol and a small brush to remove excess rosin from joints.

e. After the multimeter has been repaired, go over all new parts with moistureproof and fungiproof varnish.

f. A systematic procedure should be developed in checking the multimeter. Follow the calibration procedures in paragraphs 51 and 52, using the trouble-shooting chart (par. 50), and make the necessary repairs until the meter calibrates properly.

50. Trouble-shooting Chart

a. GENERAL. The following chart is supplied as an aid in locating trouble in the multimeter. The chart lists the symptoms which the repairmen may observe either visually or audibly, while making a few simple tests. *The chart also indicates how to localize trouble quickly to a particular stage or circuit.* Once the trouble has been localized to a stage or circuit, a tube check and voltage and resistance measurements of this stage or circuit should ordinarily be sufficient to isolate the defective part. Normal resistance and voltage measurements are given in figures 16 and 17. Capacitor and resistor color codes are shown in figures 18 and 19.

b. TROUBLE-SHOOTING CHART FOR MULTIMETER TS-505/U.

Switch position		Abnormal indication	Probable fault	Remedial action
S1	S2			
1. Any except OFF.	Any.	Pilot light does not go on; no movement of meter; age normal.	<ul style="list-style-type: none"> a. A-c line plug is not properly inserted in socket. b. Burned-out fuse F1, F2. c. Defective a-c line cord. d. Defective snap switch, S1, section 7. e. Defective transformer, T1. f. Short across filament winding of transformer T1. g. Pilot lamp burned out. 	<ul style="list-style-type: none"> a. Insert correctly. b. Replace defective fuse. c. Replace or repair line cord. d. Replace or repair switch. e. Replace transformer. f. Locate and remove short. g. Replace E13.
2. +DC.	Any.	Meter pointer does not move during initial warm-up period; pilot light on.	<ul style="list-style-type: none"> a. Bad tubes V3, V4, V5, V6, V7 and V8 b. Poor contact at socket X3, X4, X5, X6, X7, and X8. c. Meter (MI) burned out. d. Defective resistor, R4. e. Defective or dirty switch deck. f. Line voltage too low. 	<ul style="list-style-type: none"> a. Check tubes; replace defective tube or tubes. b. Clean and tighten contacts of socket; replace defective socket or sockets. c. Replace meter. d. Replace resistor. e. Clean or replace defective deck. f. Apply correct line voltage.

b. TROUBLE-SHOOTING CHART FOR MULTIMETER TS-505/U (contd)

Switch position		Abnormal indication	Probable fault	Remedial action
S1	S2			
			<i>g.</i> No voltage at cathode of V8.	<i>g.</i> Check V8 and T1; replace if defective.
3. +DC.	2V	Meter pointer is near zero but cannot be adjusted to zero with R10.	<i>a.</i> R14 defective. <i>b.</i> R10 defective. <i>c.</i> Line voltage too high or too low. <i>d.</i> Defective tube, V3 through V7. <i>e.</i> R9, R11, open or shorted.	<i>a.</i> Replace R14. <i>b.</i> Replace R10. <i>c.</i> Apply correct line voltage. <i>d.</i> Replace defective tube. <i>e.</i> Replace defective resistor.
4. +DC.	<i>a.</i> 1000V. <i>b.</i> 400V. <i>c.</i> 200V.	Meter drifts until off scale.	<i>a.</i> R24 open (grid of V3 to COMMON binding post should measure 75,000 ohms); dirty or open contact on S2. <i>b.</i> Same probable fault as subparagraph a above. <i>c.</i> R22 open (grid of V3 to COMMON binding post should measure 150,000 ohms); dirty or open contact on S2.	<i>a.</i> Replace R24; clean contact. <i>b.</i> Same remedy as subparagraph a above. <i>c.</i> Replace R22; clean contact.

Switch position		Abnormal indication	Probable fault	Remedial action
S1	S2			
	<i>d.</i> 100V.		<i>d.</i> R21 open (grid of V3 to COMMON binding post should measure 300,000 ohms); dirty or open contact on S2.	<i>d.</i> Replace R21; clean contact
	<i>e.</i> 40V.		<i>e.</i> R20 open (grid of V3 to COMMON binding post should measure 750,000 ohms); dirty or open contact on S2.	<i>e.</i> Replace R20; clean contact.
	<i>f.</i> 20V.		<i>f.</i> R19 open (grid of V3 to COMMON binding post should measure 1.5 meg. ohms); dirty or open contact on S2.	<i>f.</i> Replace R19; clean contact.
	<i>g.</i> 10V.		<i>g.</i> R18 open (grid of V3 to COMMON binding post should measure 3.0 meg-ohms); dirty or open contact on S2.	<i>g.</i> Replace R18; clean contact.
	<i>h.</i> 4V.		<i>h.</i> R16 open (grid of V3 to COMMON binding post should measure 7.5 meg-ohms); dirty or open contact on S2.	<i>h.</i> Replace R16; clean contact

b. TROUBLE-SHOOTING CHART FOR MULTIMETER TS-505/U (contd)

Switch position		Abnormal indication	Probable fault	Remedial action
S1	S2			
	<i>i.</i> 2V		<i>i.</i> R15 open (grid of V3 to COMMON binding post should measure 15 meg-ohms); dirty or open contact on S2.	<i>i.</i> Replace R15; clean contact.
5. +DC.	2V.	Application of 2V :1% to meter results in error greater than 4%.	<ul style="list-style-type: none"> a. R4 has the wrong value. b. R12 open. c. Resistors R15 through R24 are not within 1% of correct value. d. Meter (M) error greater than $\pm 2\%$. 	<ul style="list-style-type: none"> a. Replace R4. b. Replace R12. c. Find wrong resistor or resistors and replace. d. Replace meter.
6. +DC.	400V.	Apply approximately 400 v to d-c probe and then turn switchS2 to IOOOV position. Meter does not read 400 v on 1000V range.	R23 short-circuited.	Locate short circuit and repair.
7. \pm DC.	See item 4 above.	Meter drifts until off scale.	See item 4 above.	See item 4 above.
8. \pm DC.	Any.	Meter pointer not at midscale.	a. R8 set incorrectly.	a. Refer to paragraph 52&g h, i, and j.

Switch position		Abnormal indication	Probable fault	Remedial action
S1	S2			
			<i>b.</i> R7, R8 open or shorted.	<i>b.</i> Replace defective resistor or resistors.
9. -D C.	See item 4 above.	Meter drifts until off scale.	See item 4 above.	See item 4, above.
10. -D C.	2V.	Meter set to zero on +D C indicates negative when switched to -D C and cannot be set to zero with Rio.	V3 gassy.	Check condition of V3 by placing a short-circuit from grid of V3 to COMMON binding post. If shift on meter is more than 1 division, replace V3. Refer also to paragraph 48.
11. +D C. -D C, or -D C.	2V.	Zero shifts in going from 2V to 4V, etc.	V3 gassy.	See item 10 above.
12. +D C, -D C, or -D C.	Any.	Meter deflects in wrong direction.	Meter leads reversed.	Reverse meter leads.
13. +D C, + D C, or -D C.	Any.	Meter unstable; for constant input voltage, meter indication keeps changing.	<i>a.</i> V3 gassy. <i>b.</i> R12 open.	<i>a.</i> Replace V3. <i>b.</i> Replace R12.
14. +D C. -D C, or -D C.	Any.	No deflection with d-c voltage applied.	<i>a.</i> R2 open. <i>b.</i> Test lead open.	<i>a.</i> Replace R2. <i>b.</i> Replace test lead.

b. TROUBLE-SHOOTING CHART FOR MULTIMETER TS-505/U (contd)

Switch position		Abnormal indication	Probable fault	Remedial action
S1	S2			
15. +DC, ±DC, or --DC.	Any.	Application of low frequency (approx 30 cps) to d-c probe causes meter pointer to vibrate.	a. C4 open. b. C6 open	a. Replace C4. b. Replace C6.
16. OHMS.	Any.	Batteries in place, no deflection.	Short between OHMS and COMMON binding posts.	Locate and remove short.
17. OHMS.	Any.	Batteries in place, no deflection.	Batteries improperly inserted (positive or negative terminals of battery connected together.)	Insert properly, observing polarity.
18. OHMS.	Any.	Meter pointer drifts upscale.	No batteries.	Insert batteries observing polarity.
19. OHMS.	Any.	Meter pointer deflects against left hand stop.	Batteries inserted with polarity reversed.	Reverse batteries, observing polarity.
20. OHMS.	a. RX1. b. RX10 c. RX100. d. RX1000I e. RX100K. f. RX1000K g. RX1000K.	Meter drifts upscale.	a. R32 open. b. Replace R33. c. R34 open. d. R35 open. e. R36 open. f. B37 open. g. R38 open.	a. Replace R32. b. R33 open. c. Replace R34. d. Replace R35. e. Replace R36. f. Replace R37. g. Replace R38.

Switch position		Abnormal indication	Probable fault	Remedial action
S1	S2			
21. OHMS.	Any.	Full clockwise rotation of OHM ADJ does not bring meter pointer to infinity.	a. Low battery voltage. b. R3 defective.	a. Replace batteries. b. Replace R3.
22. OHMS.	Any.	Full counterclockwise rotation of OHM ADJ does not bring meter pointer below infinity.	a. Wrong batteries. b. R3 defective. c. See item 20.	a. Replace with BA-30. b. Replace R3. c. See item 20.
23. A C.	2V.	Meter cannot be set to zero with R10 or R39 (no input voltage to a-c probe).	a. R1 open or shorted, or of incorrect value. b. R25 through R31 open or shorted, or of incorrect value.	a. Replace with spare diode assembly. b. Find incorrect resistor and replace.
24. A C.	Any.	No meter deflection with ac applied to a-c probe.	a. C1 open. b. V1 burned out. c. Defective a-c probe cable.	a. Replace with a-c probe shell. b. Replace with spare diode assembly. c. Replace a-c probe cable.
25. A C.	Any.	Meter deflects with d-c voltage applied to a-c probe.	C1 defective.	Replace a-c probe shell.
26. A C.	Any.	R5 will not adjust meter for R5 open or shorted. calibrating.	Replace R5.	

b. TROUBLE-SHOOTING CHART FOR MULTIMETER TS-505/U (contd)

Switch position		Abnormal indication	Probable fault	Remedial action
S1	S2			
27. A C	Any.	Meter deflects positive with no input voltage; rotation of R39 has no effect.	<p>a. Replace with V2.</p> <p>b. R25 through R31 open or shorted, or of incorrect value.</p> <p>c. R39 defective.</p>	<p>b. Locate defective resistor or resistors and replace.</p> <p>c. Replace R39.</p>
28. A C.	Any.	Meter deflects negative with no input voltage; rotation of R39 has no effect.	<p>a. V1 inoperative.</p> <p>b. Filament lead to V1 open.</p> <p>c. R1 open.</p> <p>d. R39 defective.</p>	<p>a. Replace with spare diode assembly.</p> <p>b. Repair a-c probe cable.</p> <p>c. Replace with spare diode assembly.</p> <p>d. Replace R39.</p>
29. A C.	Any.	Meter deflects positive with no input voltage; indication on meter varies as bend is brought near case or a-c probe.	<p>a. Shields on a-c probe cable defective.</p> <p>b. Pick-up on case.</p>	<p>a. Replace a-c probe cable.</p> <p>b. Connect CASE to a good ground.</p>
30. A C.	Any.	Application of low-frequency a-c voltage gives lower deflection than high-frequency voltage.	C4 open.	Replace C4.

Switch position		Abnormal indication	Probable fault	Remedial action
S1	S2			
31. A C.	Any.	Application of low-frequency a-c voltage gives higher output than high-frequency voltage.	C2 or C3 open.	Replace defective capacitor.
32. Any except OFF.	2V.	No B+ at cathode of V8; pilot light glows.	a. V8 defective. b. C8 shorted. c. High-voltage winding of T1 open or shorted.	a. Replace VS. b. Replace C8. c. Replace T1.
33. Any except OFF.	2V.	No B+ at plates of V5; pilot light glows.	a. C9 shorted. b. R42 open. c. V8 defective.	a. Replace C9. b. Replace R42. c. Replace V8.

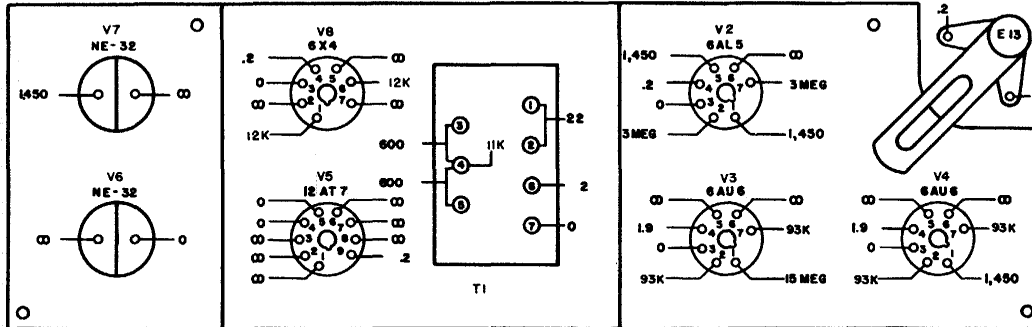

- NOTES**
1. ALL SOCKETS VIEWED FROM BOTTOM
 2. ALL POTENTIOMETERS AT MECHANICAL CENTER
 3. RANGE SWITCH AT 2V POSITION; FUNCTION SWITCH AT +DC POSITION.
 4. MEASUREMENTS MADE BETWEEN DESIGNATED POINTS AND COMMON BINDING POST
 5. UNLESS OTHERWISE SPECIFIED, RESISTORS ARE IN OHMS.

TM 5511-16

Figure 16. Electronic Multimeter TS-505/U, tube socket resistance diagram.

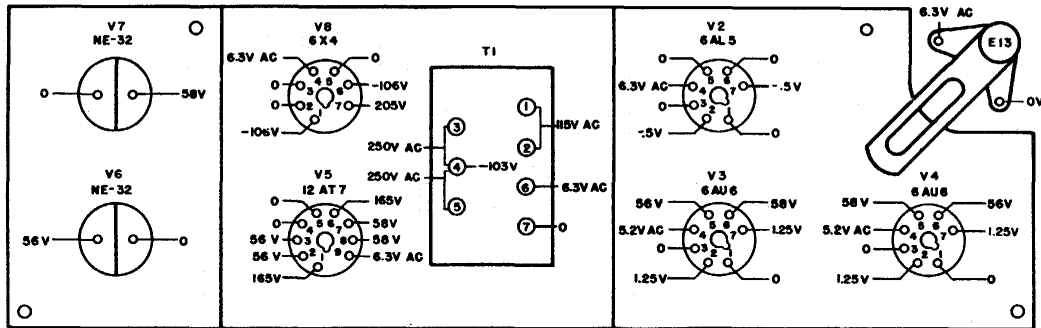

- NOTES**
1. ALL SOCKETS VIEWED FROM BOTTOM
 2. ALL POTENTIOMETERS AT MECHANICAL CENTER
 3. ALL MEASUREMENTS MADE WITH 20,000-OHMS-PER-VOLT METER
 4. ALL MEASUREMENTS ARE DC EXCEPT AS OTHERWISE NOTED
 5. RANGE SWITCH AT 2V POSITION; FUNCTION SWITCH AT +DC POSITION
 6. MEASUREMENTS MADE BETWEEN DESIGNATED POINTS AND COMMON BINDING POST
 7. LINE VOLTAGE 115V AC

TM 5511-17

, tube socket voltage diagram.

Figure 17. Electronic Multimeter TS-505/U, tube socket voltage diagram.

CAPACITOR COLOR CODES

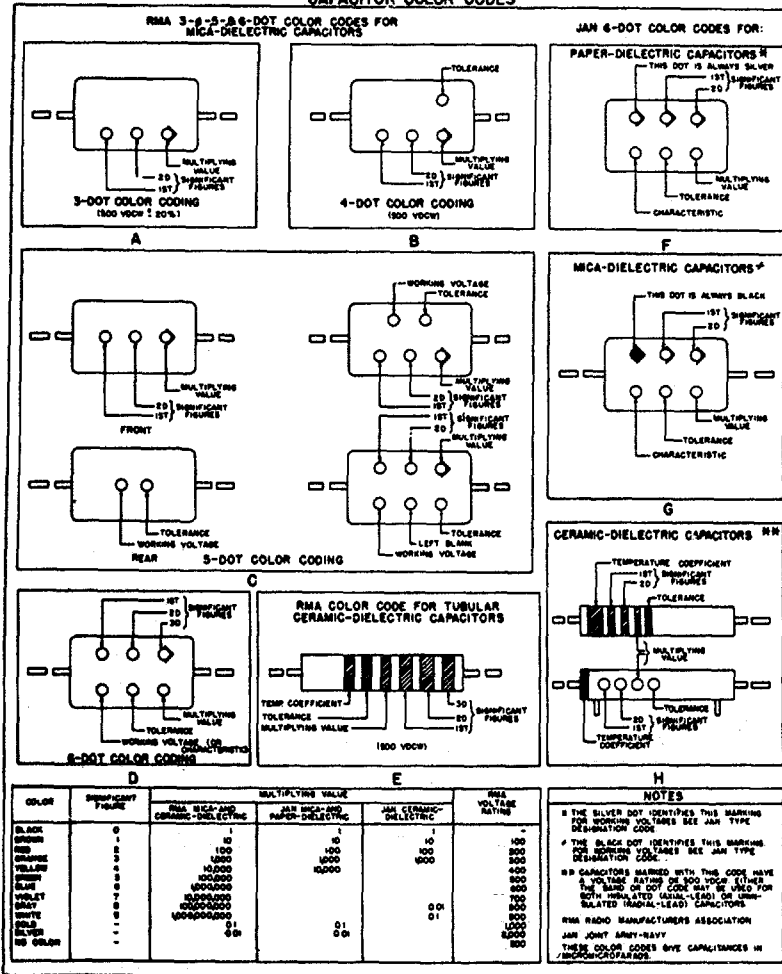
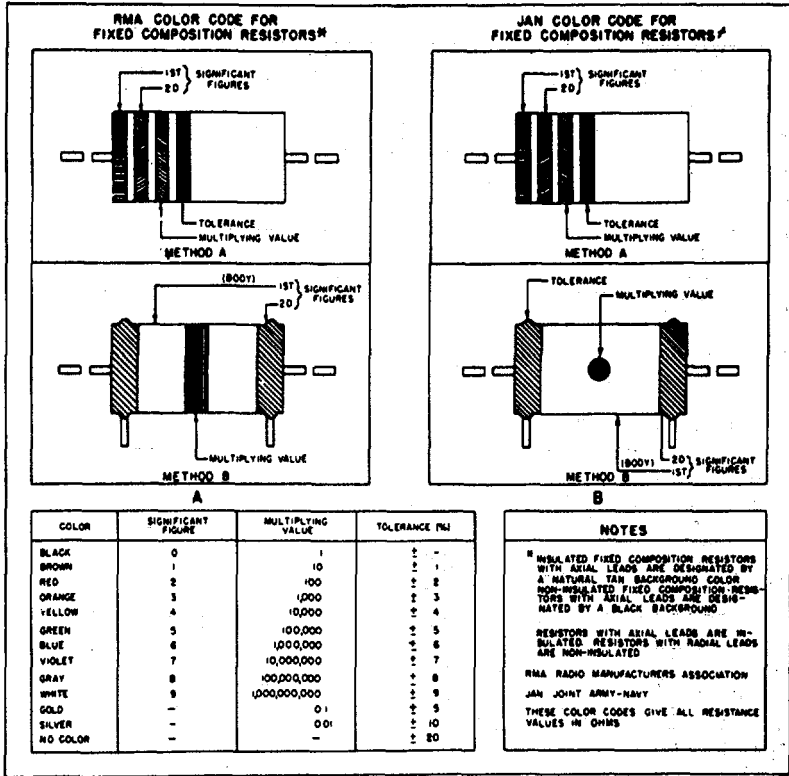

Figure 18. Capacitor color codes.

RESISTOR COLOR CODES



TL324545

Figure 19. Resistor color codes.

Section IV. CALIBRATION PROCEDURES

51. General

a. Electronic Multimeter TS-505/U is calibrated during manufacture. After calibration, resistors R3, R5, R18, and R39 are locked in place. Recalibration is not required unless the tubes are replaced, or it is definitely known that adjustments must be made. For example, recalibration is required if operating the ZERO ADJ control does not bring the meter pointer to the zero position on the meter despite the fact that control is available.

b. The calibration controls are illustrated in figures 13, 14, and 15.

52. Setting Zero Controls

a. Plug the multimeter into the power line socket (100 to 130 volts, 50 to 1,600 cps). Turn the FUNCTION switch to +D C and allow the multimeter to warm up for about 10 to 15 minutes.

b. Set ZERO ADJ resistor R10 to its mechanical center. Connect the d-c probe to the COMMON binding post. Operate the RANGE switch to the 2V position.

c. Loosen the locknut on resistor R14.

d. Rotate resistor R14 until the meter pointer is within 1/2 division of the zero position. Wait approximately 1 minute between the settings since the action of this control is sluggish.

e. Tighten the locknut on resistor R14. Be careful not to disturb the setting of the control.

f. Set the meter pointer to the zero position by operating the ZERO ADJ resistor.

g. Operate the FUNCTION switch to the \pm DC position.

h. Loosen the locknut on resistor R8.

i. Rotate resistor R8 until the meter pointer is at midscale.

j. Tighten the locknut on resistor R8. Be careful not to disturb the setting of the control.

k. Operate the FUNCTION switch to the -DC position. The meter pointer should be within 1 division of zero. If the meter pointer is out-side the range of control by the ZERO ADJ resistor, refer to paragraph 48 for corrective procedure.

l. Operate the FUNCTION switch to the OHMS position. The meter pointer should read upscale. Adjust the meter pointer to ∞ by operating the OHM ADJ control R3.

m. Operate the FUNCTION switch to the AC position.

n. Loosen the locknut on resistor R39.

- o. Adjust resistor R18 until the meter pointer is in the zero position.
- p. Tighten the locknut on resistor R39. Be careful not to disturb the setting of the control.
- q. Operate the FUNCTION switch to the D C position. Operate the RANGE switch to the 2V position.
- r. Apply 2 volts +1 percent to the d-c probe. The meter pointer should read within 4 percent. If the error is greater than this, check the resistance of resistors R4, and R15 through R24. Check the accuracy of meter M1 against a standard.
- s. Repeat the step in subparagraph r above for each range with appropriate voltages.
- t. Operate the FUNCTION switch to the OHMS position. Check the accuracy of the ohms calibration by using standard resistors known to be accurate within 1 percent. If the reading on the meter is not within 4 percent of full scale (total scale arc), check resistors R32 through R38.
- u. Operate the FUNCTION switch to the A C position. Operate the RANGE switch to the 100V position.
- v. Loosen the locknut on resistor R5.
- w. Apply 10 volts + 1 percent at 400 cps, to the a-c probe. The 400 cps must have less than .5 percent distortion.
- x. Rotate resistor R5 until the meter pointer reads full scale.
- y. Repeat the step in subparagraph w above, on the other ranges with appropriate voltages. The readings should be within +_6 percent.
- z. Tighten the locknut on resistor R5. Be careful not to disturb the setting of the control.

53. Replacement of A-c Probe Assembly

a. Because of the mechanical difficulties and special techniques needed to replace the tube in the a-c probe (fig. 20) repair of this component is not recommended. Instead, if capacitor C1 is defective, replace the a-c probe shell. If diode VI or resistor R1 is defective, replace with a spare diode assembly.

b. To replace the a-c probe shell:

(1) With one hand, grasp the diode assembly retaining screw (fig. 20) to prevent it from turning; with the other hand, loosen the waterproof sealing nut.

Caution: Do not use tools on these parts. The fingers of your hand should be sufficient.

(2) Loosen the diode assembly retaining screw. The a-c probe shell will separate from the rest of the assembly.

(3) Replace the defective a-c probe shell with a good unit.

(4) Tighten the diode assembly retaining screw.

(5) Tighten the waterproof sealing nut.

Caution: Do not attempt to disassemble the a-c probe without first loosening the waterproof sealing nut. Failure to do this may result in a broken tube. In assembling the a-c probe, the waterproof sealing nut should be tightened last.

c. To replace the spare diode assembly:

(1) With one hand, grasp the diode assembly retaining screw to prevent it from turning; with the other hand, loosen the waterproof sealing nut.

(2) Loosen the diode assembly retaining screw. The a-c probe shell will separate from the rest of the assembly.

(3) Slip the waterproof sealing nut, washer, waterproof seal, diode assembly retaining screw, and insulator over the a-c probe cable (fig. 21) to permit access to the tube base.

(4) Carefully unsolder the cable from the tube base. Tag the cable leads to permit identification when resoldering.

(5) Remove a spare diode assembly from the rear of the multimeter and carefully solder the leads from the cable to the spare diode assembly.

(6) Replace the a-c probe shell and tighten the diode assembly retaining screw.

(7) Tighten the waterproof sealing nut.

Caution: Observe the *cautions* in subparagraph b above.

d. To replace the a-c probe cable:

(1) Repeat the steps in subparagraph b(l) through (4) above at the a-c probe end of the cable. Put the waterproof sealing nut, washer, waterproof seal, diode assembly retaining screw, and insulator on the new cable in the order shown in figure 21.

(2) Repeat the steps in subparagraph b(6) and (7) above.

(3) Remove the sealing nut, washer, and waterproof seal at the multimeter end of the cable. An open-end wrench may be used on the sealing nut.

(4) Unsolder the cable leads from the terminal board. Tag the cable leads to permit identification when resoldering.

(5) Put the sealing nut, washer, and waterproof seal (in the order named) on the new cable.

(6) Solder the new cable to the terminal board.

(7) Tighten the sealing nut with an open-end wrench.

Note. Order replacements *immediately* for any parts of the a-c probe which are replaced.

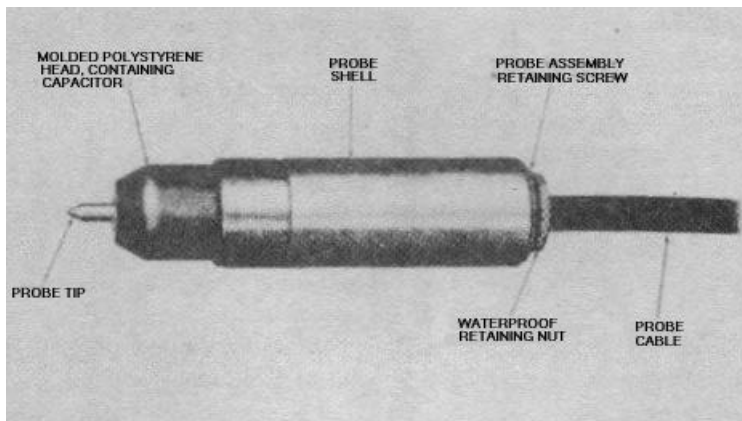

Figure 20. A-c probe.

Section V. REFINISHING

54. Appearance

a. GENERAL. Check all metal surfaces for appearance and condition of the finish. From a protective and durability standpoint, the finish should show no decided wear and should not be chipped or scratched to show any bare metal. Refinish surfaces where the finish has been removed completely or worn through or where it has been removed as a result of sanding or scratch brushing. Retouch such surfaces if the bare spots are restricted to small areas, but if the bare or damaged spots cover large areas, completely refinish the entire part. Discolored, spotted, stained, or faded surfaces are permissible provided the original finish is intact.

b. FINISHING PROCEDURES. After sanding or scratch brushing, retouch affected surfaces to match the original finish. Apply one coat of clear lacquer to parts having a bright metal finish. Apply one coat of enamel to painted surfaces. Do not apply lacquer to surfaces which might affect the mechanical or electrical function of the equipment.

55. Refinishing After Repair

After repairing Electronic Multimeter TS-505/U, repaint any unprotected surfaces. If any components in the multimeter have been replaced, repaired, or resoldered, moistureproof and fungiproof the component with varnish. After the varnish has dried, place the unit in the back cover and tighten with the holding screw. Be careful not to strip the threads.

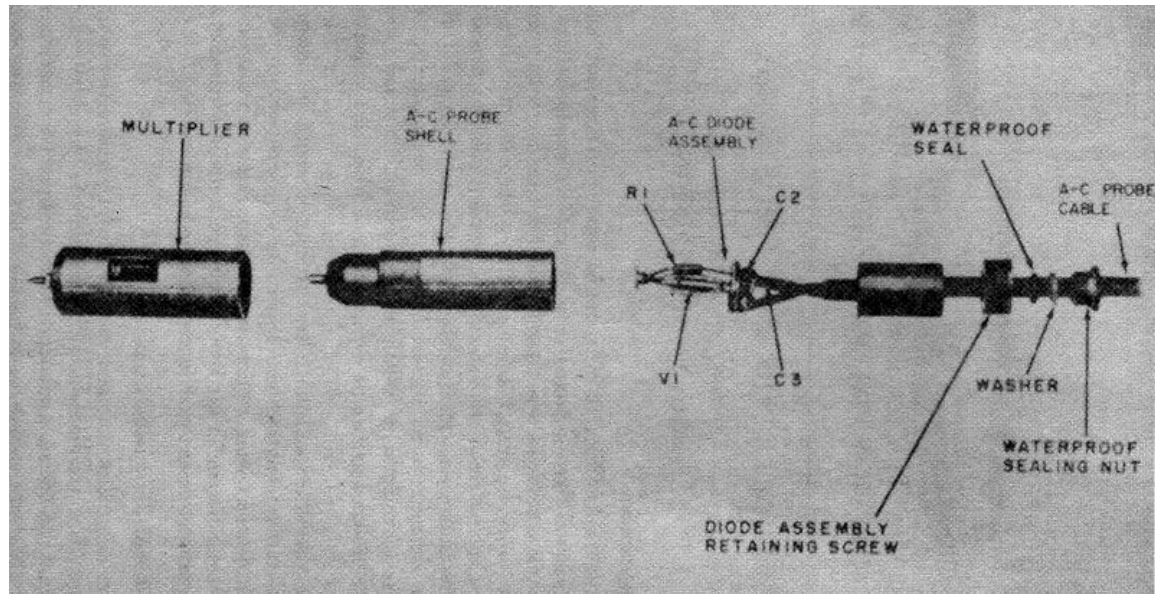

Figure 21. Exploded view of a-c probe.

**CHAPTER 5
SHIPMENT AND LIMITED STORAGE AND
DEMOLITION TO PREVENT ENEMY USE**

Section I. SHIPMENT AND STORAGE

Note. The circumstances involved in shipment and storage vary, and therefore no definite procedure for repacking can be given. The following instructions are recommended as a guide for preparing Electronic Multimeter TS-S05/U for transportation and storage.

56. Removal from Service

- a. Disconnect the multimeter from the power supply.
- b. Place the probes into their respective compartments. Place the power cord into its compartment.
- c. See that all tubes are seated firmly in their sockets.
- d. Fasten the covers in place.

57. Repacking for Shipment or Limited Storage

a. The exact procedure in repacking for shipment or limited storage depends on the material available and the conditions under which the equipment is to be shipped or stored. Refer to paragraph 9b and figure 4, and follow the instructions in reverse order.

b. Whenever possible, place a dehydrating agent such as silica gel inside the equipment. Protect the equipment with a waterproof paper barrier. Seal the seams of the paper barrier with a waterproof sealing compound or tape. Pack the protected equipment in a padded fiber-board box.

Section II. DEMOLITION TO PREVENT ENEMY USE

58. Methods of Demolition

- a. SMASH. Use sledges, axes, handaxes, pickaxes, hammers, crowbars, heavy tools.

b. CUT. Use axes, handaxes, machetes.

c. BURN. Use gasoline, kerosene, oil, flame throwers, incendiary grenades.

d. EXPLODE. Use firearms, grenades, TNT.

e. DISPOSE. Bury in slit trenches, fox holes, other holes; scatter. Do not throw in streams; the multimeter is waterproof and will float.

Note. Use anything immediately available for destruction of this equipment.

59. Destruction of Components

When ordered by your commander, destroy all equipment to prevent its being used or salvaged by the enemy.

a. Smash (par. 58a) the meter, tubes, resistors, switches, and capacitors.

b. Cut (par. 58b) cords and wiring.

c. Bum (par. 58c) cords, resistors, capacitors, coils, wiring, office records, and technical manual.

d. Bend the case, cover, and panel.

e. Bury or scatter (par. 58e) all remaining parts of the equipment.

DESTROY EVERYTHING

APPENDIX I

REFERENCES

Note. For availability of items listed, check SR 310-20-3 for field manuals, training circulars, training aids, Army training programs, JANAPs, Tables of Organization and Equipments (T/O&E), Tables of Allowances (T/A), and Tables of Basic Allowances (T/BA). Check SR 310-20-4 for technical manuals, technical bulletins, supply bulletins, modification work orders, and Changes. Check Department of the Army Catalog SIG 1 for Signal Corps supply catalog pamphlets.

1. Army Regulations

AR 380-5 Safeguarding Military Information.

2. Supply Publications

SB 11-6 Dry Battery Supply Data.

SB 11-47 Preparation and Submission of Requisitions for Signal Corps Supplies.

SB 11-76 Signal Corps Kit and Materials for Moisture and Fungi-Resistant Treatment.

3. Technical Manuals on Test Equipment

TM 11-303 Test Sets 1-56-C, -D, -H, and -J.
TM 11-321 Technical Manual for Test Set 1-56-E.
TM 11-472 Repair and Calibration of Electrical Measuring Instruments.
TM 11-2613 Voltohmmeter 1-166.
TM 11-2626 Test Unit 1-176.
TM 11-2627 Tube Tester 1-177.

4. Painting, Preserving, and Lubrication

TB SIG 13 Moistureproofing and Fungiproofing Signal Corps Equipment.
TM 9-2851 Painting Instructions for Field Use.

5. Decontamination

TM 3-220 Decontamination.

6. Demolition

FM 5-25 Explosives and Demolitions.

7. Packaging and Packing Instructions

a. JOINT ARMY-NAVY PACKAGING SPECIFICATIONS.

JAN-D-169	Desiccants, Activated.
JAN-P-100	General Specification.
JAN-P-106A	Boxes; Wood, Nailed.
JAN-P- 16	Preservation, Methods of.
JAN-P-125	Barrier-Materials, Waterproof, Flexible.
JAN-P-131	Barrier Material; Moisture-Vapor-proof, Flexible.

b. U.S. ARMY SPECIFICATION.

100-2E	Marking Shipments by Contractors (and Signal Corps Supplement thereto).
100-14A	Army-Navy General Specification for Packaging and Packing for Overseas Shipment.

c. SIGNAL CORPS INSTRUCTIONS.

720-7	Standard Pack.
726-15	Interior Marking.

8. Other Publications

SR 310-20-3	Index of Army Training Publications (Field Manuals, Training Circulars, Firing Tables and Charts, Army Training Programs, Mobilization Training Programs, Graphic Training Aids, Joint-Army-Navy-Air Force Publications, and Combined Communications Board Publication).
-------------	--

SR 310-20-4	Index of Technical Manuals, Technical Regulations, Technical Bulletins, Supply Bulletins, Lubrication Orders, Modification Work Orders,
-------------	---

Tables of Organization and Equipment, Reduction
Tables, Tables of Allowances, Tables of Organization,
Tables of Equipment, and Tables of Basic Allowances.

TB SIG 123

Preventive Maintenance Practices for
Ground Signal Equipment.

TM 11-490

Electrical Fundamentals.

TM 11-453

Shop Work.

TM 11-455

Radio Fundamentals.

TM 11-660

Introduction to Electronics.

TM 11-4000

Trouble Shooting and Repair of Radio Equipment.

TM 38-650

Basic Maintenance Manual.

APPENDIX II

IDENTIFICATION TABLE OF PARTS FOR ELECTRONIC MULTIMETER TS-505/U

Note. The fact that a part is listed in this table is not sufficient basis for -requisitioning the item. Requisitions must cite an authorized basis, such as T/O&E, T/A, SIG 6, SIG 7&8, SIG 7.8-10, SIG 10, list of allowances of expendable material, or another authorized supply basis. The Department of the Army Supply Catalog applicable to the equipment covered in this instruction book is SIG 7&8-TS-505/U. For an index of available catalogs in the Signal portion of the Department of the Army Supply Catalog, see the latest issue of SIG 1, Introduction and Index.

Identification Table of Parts for Electronic Multimeter TS505/U (contd)

Ref symbol	Name of part and description	Function of part	Signal Corps stock No.
	ELECTRONIC MULTIMETER TS-505/U: electronic type, 115 v a, 50 to 1600 cyc; 0 to 1000 v dc in 9 steps, 0 to 500 v dc w/ o ctr in 9 steps, 0 to 200 v ac in 7 steps, 0 to 1000 meg in 7 steps.	Measures ac and d-c voltages and resistances of electronic equipment over relatively wide ranges.	3F4325-505
BA-1,	BATTERY: JAN type BA-30; 1/2 v; specification JAN B18A.	Supplies voltage to ohmmeter	3A30
BA-2	CABLE, power: 2 #18 AWG stranded cond.	section. Connects multimeter to a-c power source.	1B818.14
	CABLE, power: a-c probe cable; 3 #18 AWG stranded copper cond; 16 #30 AWG strands; 300 v working; Specialty Packing part No. 123E-1-F.	Connects test prod assembly to multimeter.	1B3018-3.8
C1	CAPACITOR, fixed; ceramic; 6000 uuf; part of ac probe assembly.	Input coupling capacitor.	
C2, C3	CAPACITOR, fixed: ceramic; 1000 uuf +100% -0; 200 vdcw; Specialty Packing part No. 123E-1-5.	Bypass rf in a-c probe.	3DA1-287
C4	CAPACITOR, fixed: paper; .01 uf :20%; 1000 vdcw; JAN type No. CN43A103M.	Bypasses ac.	3DA10-450
C5, C6	CAPACITOR, fixed: paper; .01 uf +20%; 400 vdcw; JAN type No. CN30E103M.	Same as C4.	3DA10-437
C7	CAPACITOR, fixed: paper; .02 uf +-20%; 200 vdcw; JAN type No. CN22E203M.	Same as C4.	3DA20-246
C8, C9	CAPACITOR, fixed: paper; 2 uf +10%; 600 vdcw; JAN type No. CP53B1EF205K-	Filter power supply.	3DB2-143
C10	CAPACITOR, fixed: ceramic; .0001 uf t20%; 500 vdcw; Erie part No. GP2-331-100±10.	High frequency bypass.	3D9100-289

Identification Table of Parts for Electronic Multimeter TS-505/U (contd)

Ref symbol	Name of part and description	Function of part	Signal Corps stock No.
P1	CONNECTOR, male contact: Harvey Hubbell No. 7057.	A-c line plug.	6Z1727
F1, F2, F3, F4	FUSE, cartridge: 1 amp; Littelfuse type 3AG.	F1, F2-Line fuses; protect the multimeter from overload. F3, F4-Spare fuses.	3Z1926
K3, K4	KNOB: bar; black bakelite; Harry Davies Mold No. 2300A	K3-Knob for FUNCTION switch (S1). K4-Knob for RANGE switch (S2).	2Z5838
K1, K2	KNOB: round; black bakelite; Harry Davies Mold No. 1450W.	K1-Varies R3. K2-Varies R10.	25821-4
E13	LAMP, incandescent: 6.3 v, .15 amp; miniature screw base; GE type 47.	Indicates the presence of line voltage.	2Z5952
J1	LAMPHOLDER: miniature screw base; Specialty Packing part No. 123E-12.	Holds E13.	2Z5988-38
W1	LEAD, test: black; Sig C No. CX-1331/U; test prod will accept Specialty part No. 150G-1-C alligator clip; Specialty Packing part No. 123E-1-A.	Test lead.	3E8000-53
W2	LEAD, test: red; Sig C No. CX-1331/U; test prod will accept Specialty part No. 150G-1-C alligator clip; Specialty Packing part No. 123E-1-B.	Same as W1.	3E8000-53.1
M1	METER, ammeter: de; 0 to 1 ma; QVS No. 450.	Indicates the magnitude of voltage and resistance.	3FS91-89
E1, E2, E3	POST, binding: screw type; Specialty Packing part No. 123E-1-26.	E1--OHMS terminal post. E2--COMMON terminal post.	3Z737-56

Identification Table of Parts for Electronic Multimeter TS-505/U (contd)

Ref symbol	Name of part and description	Function of part	Signal Corps stock No.
E4	PROD, test: red; plastic body; contains R2; Specialty Packing part No. 123E-1-2.	E3-CASE terminal post. D-c probe.	3F3705-12.2
E5	PROD ASSEMBLY, test: ac probe; consists of ac probe shell, diode assembly. waterproof sealing nut, washer, waterproof seal, diode assembly retaining screw, and insulator.	A-c probe and rectifies a-c voltage.	3F3705-20
R1	RESISTOR, fixed: composition 15meg $\pm 5\%$; 1/2 w; JAN type No. RC20BF156J; part of a-c probe assembly.	Load resistor for a-c probe.	
R2	RESISTOR, fixed: composition; 5meg $\pm 1/2\%$; 1/2 w; Wilkor Products type CP 1/2.	D-c probe isolation resistor.	3Z6805-44
R3	RESISTOR, variable: composition; 2500 $\pm 20\%$; 2 w; Specialty Packing part No. 123E-1-66.	OHM ADJ resistor.	3Z7325-43
R4	RESISTOR, fixed: composition; 1450 ohms $\pm 1/2\%$; 1/2 w; Wilkor Products type CPS 1/2.	D-c calibration resistor.	3Z6450-32
R5	RESISTOR, variable: composition; 2500 ohms $\pm 20\%$; 2 w; Specialty Packing part No. 123E-1-67.	A-c calibration resistor.	3Z7325-44
R7	RESISTOR, fixed: composition; 100,000 ohms $\pm 10\%$; 1 w; JAN type No. RC30BF104K.	Zero center current limiting resistor.	3RC30BF104K
R8	RESISTOR, variable: composition; 50,000 ohms $\pm 20\%$; 2 w; Specialty Packing part No. 123E-1-65.	Zero center calibration resistor.	3Z7450-140
R9, R11	RESISTOR, fixed: 150,000 ohms $\pm 5\%$; 1/2 w; JAN type No. RC20BF154J.	R9-V3 plate load resistor. R11-V4 plate load resistor.	3RC20BF154J

Identification Table of Parts for Electronic Multimeter TS-505/U (contd)

Ref symbol	Name of part and description	Function of part	Signal Corps stock No.
R10	RESISTOR, variable: composition; 25,000 ohms \pm 20%; 2 w; Specialty Packing part No. 123E-1-112.	ZERO ADJ resistor.	3Z7425-99
R12	RESISTOR, fixed: composition; 200,000 ohms \pm 5%; 1/2 w; JAN type No. RC20BF204J.	Regeneration control resistor.	3RC20BF204J
R13	RESISTOR, fixed: composition; 82,000 ohms \pm 5%; 1/2 w; JAN type No. RC20BF823J.	Bias resistor for V3 and V4.	3RC20BF823J
R14	RESISTOR, variable: wire wound; 6 ohms; \pm 10%; .1 w; JAN type No. RA15A1SD6ROAK.	Coarse zero adjustment.	3Z7006-13
R15	RESISTOR, fixed: composition; 7.5meg \pm 1/2%; 1/2 w; Wilkor Products type CPL 1/2.	Voltage dropping resistor of d-c attenuator.	3Z6807E5-2
R16	RESISTOR, fixed: composition; 4.5meg \pm 1/2%; 1/2 w; Wilkor Products type CP 1/2.	Voltage dropping resistor of d-c attenuator.	3Z6804E5-1
R17A,	RESISTOR, fixed: composition; consists of two 18meg \pm 5%; /4w;	Four-volt, a-c linearity corn-	3RC10BF186J
R17B	JAN type No. RC10BF186J.	pensating resistor.	
R18	RESISTOR, fixed: composition; 1.5meg \pm 1/2%; 1/2 w; Wilkor Products type CPS 1/2.	Voltage dropping resistor of d-c attenuator.	3Z6801E54
R19	RESISTOR, fixed: composition; 750,000 ohms \pm 1/2%; 1/2 w; Wilkor Products type CPS 1/2.	Same as R18.	3Z6775-40
R20	RESISTOR, fixed: composition; 450,000 ohms \pm 1/2%; 1/2 w; Wilkor Products type CPS 1/2.	Same as R18.	3Z6745-15
R21	RESISTOR, fixed: composition; 150,000 ohms \pm 1/2%; 1/2 w; Wilkor Products type CPS 1/2	Same as R18.	3Z6715-88

Identification Table of Parts for Electronic Multimeter TS-505/U (contd)

Ref symbol	Name of part and description	Function of part	Signal Corps stock No.
R22,	RESISTOR, fixed: composition; 75,000 ohms \pm 1/2%; 1/2 w; Wilkor	Same as R18.	3Z6675-109
R24	Products type CPS .2-		
R23	RESISTOR, fixed: composition; 30meg \pm 1/2%; 1 w; Wilkor Products type CP 1.	Same as R18.	3Z6830-2
R25	RESISTOR, fixed: composition; 2.5meg -1%; 1/2 w; Wilkor Products type CP 1/2.	Voltage dropping resistor of diode balancing attenuator.	3Z6802E5-1
R26	RESISTOR, fixed: composition; 1.5meg \pm 1%; 1/2 w; Wilkor Products type CP 1/2.	Same as R25.	3Z6801E5-3
R27	RESISTOR, fixed: composition; 500,000 ohms + 1%; 1/2 w; Wilkor Products type CP 1/2.	Same as R25.	3Z6750-117
R28	RESISTOR, fixed: composition; 250,000 ohms \pm 1%; 1/2 w; Wilkor Products type CP 1/2.	Same as R25.	3Z6725-87
R29	RESISTOR, fixed: composition; 150,000 ohms \pm 1%; 1/2 w; Wilkor Products type CP 2.	Same as R25.	3Z6715-82
R30,	RESISTOR, fixed: composition; 50,000 ohms \pm 1%; 1/2 w; Wilkor	Same as R25.	3Z6650-216
R31	Products type CP 1/2.		
R32	RESISTOR, fixed: composition; 30 ohms \pm 1%; 1 w; Wilkor Products type CP 1.	Ohmmeter resistor for RX1.	3Z6003-76
R33	RESISTOR, fixed: composition 300 ohms \pm 1%; 1/2 w; Wilkor Products type CPS 1/2.	Ohmmeter resistor for RX10.	3Z6030-136
R34	RESISTOR, fixed: composition; 3000 ohms \pm 1%; 1/2 w; Wilkor Products type CPS 1/2.	Ohmmeter resistor for RX100.	3Z6300-224

Identification Table of Parts for Electronic Multimeter TS505/U (contd)

Ref symbol	Name of part and description	Function of part	Signal Corps stock No.
R35	RESISTOR, fixed: composition; 30,000 ohms \pm 1%; 1/2 w; Wilkor Products type CPS 1/2	Ohmmeter resistor for RX1000.	3Z6630-121
R36	RESISTOR, fixed: composition; 300,000 ohms \pm 1%; 1/2 w; Wilkor Products type CPS 1/2.	Ohmmeter resistor for RX10K.	3Z6730-54
R37	RESISTOR, fixed: composition: 3 meg \pm 1%; 1/2 w; Wilkor Products type CP 1/2.	Ohmmeter resistor for RX100K.	3Z6803-33
R38	RESISTOR, fixed: composition; 30 meg \pm 1%; 1 w; Wilkor Products type CP 1.	Ohmmeter resistor for RXIMEG.	3Z(830-1
R39	RESISTOR, variable: composition; 5 meg \pm 20%; 2 w; Specialty Packing part No. 123E-1-43.	A-c zero adjustment resistor.	3Z7499-5.21
R40,	RESISTOR, fixed: composition; 22,000 ohms \pm 5%; 1 w; JAN type	R40-Load resistor for V6.	3RC30BF223J
R41	No. RC30BF223J.	R41-Load resistor for V7.	
R42	RESISTOR, fixed: composition; 3300 ohms \pm 10%; 1 w; JAN type No. RC30BF332K.	B+ filter resistor.	3RC30BF332K
X2, X3,	SOCKET, tube: 7-pin miniature; JAN type No. TSE7T101.	X2-Holds V2.	2Z.8677.94
X4, X8		X3-Holds V3. X4-Holds V4. X8-Holds V8.	
X5	SOCKET, tube: 9-pin miniature; JAN type No. TSE9T101.	Holds V5.	2Z8679.30
X6, X7	SOCKET, tube: 2-contact bayonet; Dial Light Co No. 6S-7.	X6-Holds V6.	2Z8672.79
S1	SWITCH, rotary: 6 pole, 6 positions; 3 laminated bakelite decks; Specialty Packing part No. 123E-1-71.	X7-Holds V7. On-off switch and function selector.	3Z9825-62.500

Identification Table of Parts for Electronic Multimeter TS-505 U (contd)

Ref symbol	Name of part and description	Function of part	Signal Corps stock No.
S2	SWITCH, rotary: 4 pole, 9 positions; 2 laminated bakelite decks; Specialty Packing part No. 123E-1-72.	Range selector switch.	3Z9825-62501
T1	TRANSFORMER, power: filament and plate type; input 115 v, 50 to 1600 cyc, single-ph; 2 output windings; secd No. 1, 6.3 v at 21/2 amp, Fecd No. 2, 500 v at 15 ma CT; 3000 v insulation primary to core and primary and secd; hermetically sealed metal case; Specialty Packing part No. 123E-1-75.	Power supply transformer	2Z9613.664
V1	TUBE, electron: part of diode assembly in a-c probe; RMA 5935.	Diode rectifier.	
V2	TUBE, electron: type 6AL5.	Balancing diode.	2J6AL5W
V3, V4	TUBE, electron: type 6AU6.	Input coupling tubes.	2J6AU6
V5	TUBE, electron: type 12AT7.	Output coupling tubes.	2J12AT7
V6, V7	TUBE, electron: type NE-32.	Voltage regulator tubes.	2J991
V8	TUBE, electron: type 6X4.	Rectifies power supply.	2J6X4

INDEX

A	<i>Paragraph</i>	<i>Page</i>
A-c line cord, location	5a	4
A-c probe:		
Description	33e	27
Location	5a	4
Replacement.....	53	59
Theory of operation	39	35
A-c voltages, measuring and reading	18	15
Accessory equipment.....	6	6
Alligator clips. (See Clips, alligator.)		
Amplifier:		
Description	33b	27
Theory of operation.....	35	30
Army regulations	app I, 1	65
B		
Binding posts. (See CASE binding post, COMMON binding post, and OHMS binding post.)		
C		
Calibration	51	58
CASE binding post:		
Description	5a	5
Use.....	15a, 33g	12, 29
Catches, for multimeter cover	3a, 9c	2, 10
Checking new equipment	9	9
Cleaning multimeter	45	41
Clips, alligator	5c	6
COMMON binding post:		
Description	5a	4
Use	15a, 33g	12, 29
Components:		
Description and location	5	4
Table	4	4
D		
Dc-probe:		
Description	33d	27

Location.....	5a	4
Theory of operation.....	38	35
D-c voltages, measuring and reading.....	17	14
Decontamination.....	app I, 5	66
Demolition.....	58, app I, 6	63, 66

E

Electronic multimeter. (See Multimeter.)

Equipment performance checklist:

List.....	22	18
Purpose and use.....	21	16

F

Forms and records.....	2	1
FUNCTION switch:		
Description.....	13, 33f	11, 29
Theory of operation.....	37a	32
Use.....	5a	4

G

Gas checks, for tubes.....	48	43
----------------------------	----	----

I

Identification table of parts.....	app II	69
Inspection of equipment.....	42	37

L

Lubrication.....	25, app I, 4	21, 65
------------------	--------------	--------

M

Manuals, technical, on test equipment.....	app I, 3	67
Materials, for repairs.....	40	37
Measurement of-		
A-c voltages.....	18	15
D-c voltages.....	17	14
Resistances.....	19	15
Meter:		
Description.....	14, 33c	12, 27
Location.....	5a	4
Scales.....	3c, 36	2, 32
Multimeter:		
Calibration.....	51	58
Cleaning.....	45	41
Description.....	3a	2

	<i>Paragraph</i>	<i>Page</i>
Equipment features	3c	2
Gas checks	48	43
Identification table of parts	app II	67
Inspection	42	37
Location.....	12	11
Maintenance.....	30	22
Operation under:		
Unusual conditions.....	23, 24	20
Usual conditions	16.22	12-19
Painting	27, app I,4	21,65
Power requirements	41	37
Preliminary starting procedure	16	12
Purpose and use	3	2
Refinishing	54	61
Multimeter-(contd)		
Removal from service.....	56	63
Repacking	11	10
Rustproofing and painting	27	21
Stopping procedure	20	16
Stripping	44	39
Technical characteristics.....	7	6
Theory of operation:		
A-c probe	39	35
Amplifier	35	30
Block diagram	33	27
D-c probe	38	35
Meter	36	32
Power supply.....	34	29
Scope and application.....	32	27
Switch section	37	32
Trouble-shooting:		
Chart	50	44
Procedures	47	42
Unpacking.....	9	9
Weatherproofing ..	26	21

O

Ohmmeter:		
Range.....	7	6
Scale.....	3	2
Use	5a	4

Ohms adjustment control.....	13d	11
OHMS binding post:		
Description	5	4
Use.....	15c, 33g	12, 29
Ohms scale, adjustment.....	19	15

P

Packaging and packing instructions	app I, 7	66
Packaging data	8	7
Painting	27, app I, 4	21, 65
Pilot light, use	5a	4
Power requirements	41	37
Power supply:		
Description	33a	27
Theory of operation	34	29
Preventive maintenance:		
Checklist	31	23
Definition and importance	28	22
Techniques:		
General	29	22
Specific.....	30	22
Probe. (See A-c probe or D-c probe.)		

R

RANGE switch:		
Description	13b, 33f	11, 29
Theory of operation	37b	33
Use	5a	4
Ranges, number of	7	6
Reading:		
A-c voltages	18	22
D-c voltages	17	14
Resistances	19	15
Records and forms	2	1
Refinishing multimeter	3b	59
Resistance:		
Measuring and reading	19	15
Ranges.....	3c	2

S

Scales of meter	3c	2
Scope of manual	1	1

	<i>Paragraph</i>	<i>Page</i>
Starting procedure, preliminary.....	16	12
Stripping multimeter.....	43	38
Supply publications	app I, 2	65
Switch:		
Function. (See FUNCTION switch.)		
Range. (See RANGE switch.)		

T

Technical characteristics of multimeter	7	6
Terminals.....	3g	29
Test equipment	40	37
Theory of operation of multimeter:		
A-c probe	39	35
Amplifier	35	30
Block diagram.....	33	27
D-c probe	38	35
Meter	36	32
Power supply	34	29
Scope and application.....	32	27
Switch section.....	37	32
Tools, for repairs	40	37
Trouble shooting:		
Chart	50	44
Gas checks	48	43
General precautions	49	43
Preliminary procedures.....	46	42
Procedures	47	42
Tubes:		
Number	7	6
Types	7	6

U

Unpacking.....	3b	2
Use of multimeter.....	9	9

V

Voltage:		
A-c, measuring and reading.....	18	15
D-c, measuring and reading.....	17	14
Ranges:		
A-c	3	2
Characteristics	7	6

	<i>Paragraph</i>	<i>Page</i>
D-c	3c	2
Zero center scale	3	3c
W		
Weatherproofing	26	21
Z		
Zero adjustment control:		
Description	13c	11
Setting	52	58
Use	5a	4

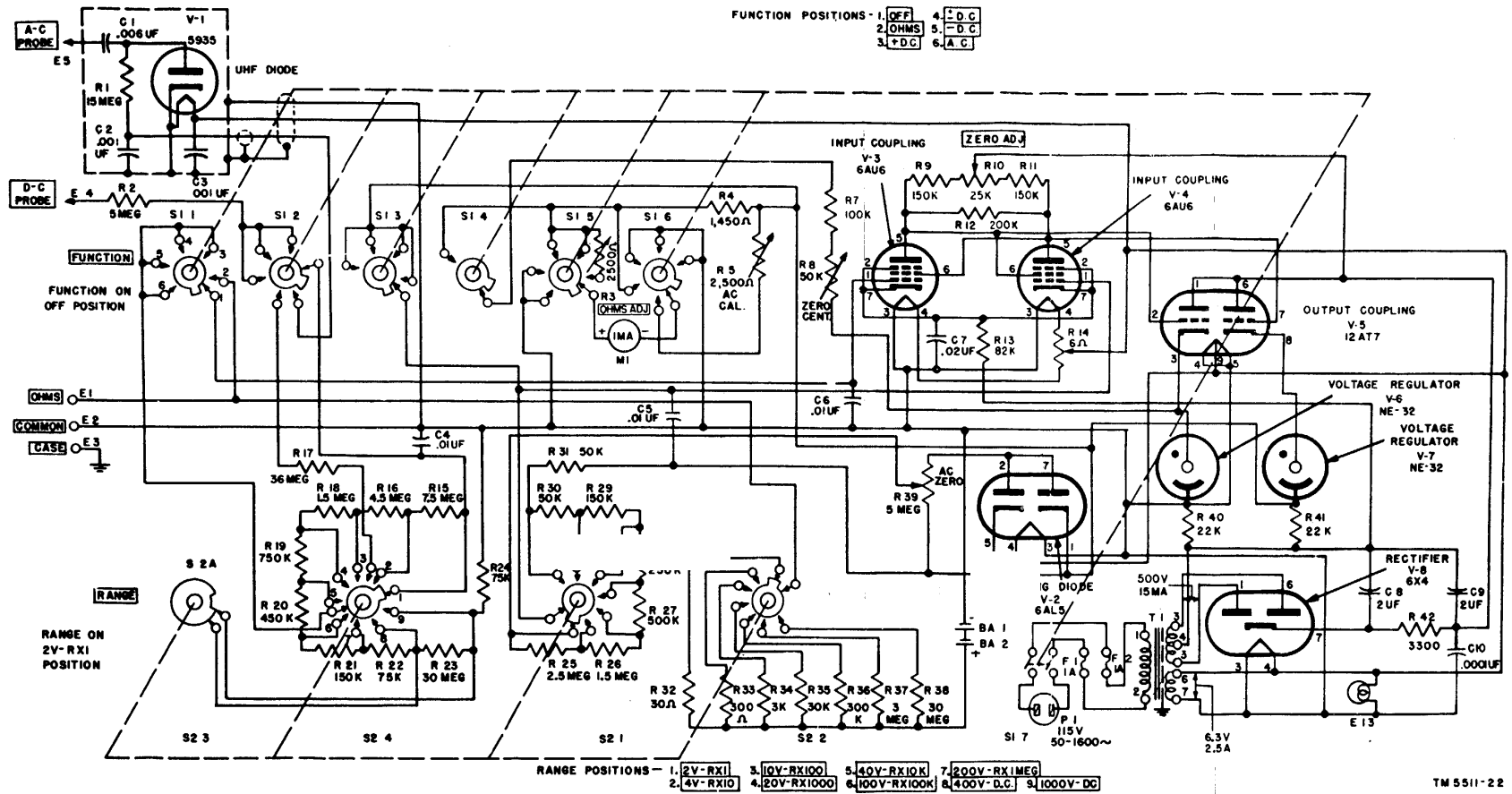

TM 5511-22

Figure 22. Electronic Multimeter TS-505/U, schematic diagram.

RECOMMENDED CHANGES TO EQUIPMENT TECHNICAL PUBLICATIONS



THEN...JOT DOWN THE DOPE ABOUT IT ON THIS FORM. CAREFULLY TEAR IT OUT, FOLD IT AND DROP IT IN THE MAIL.

SOMETHING WRONG WITH PUBLICATION

FROM: (PRINT YOUR UNIT'S COMPLETE ADDRESS)

DATE SENT

PUBLICATION NUMBER

PUBLICATION DATE

PUBLICATION TITLE

BE EXACT PIN-POINT WHERE IT IS

PAGE NO.

PARA-GRAPH

FIGURE NO.

TABLE NO.

IN THIS SPACE, TELL WHAT IS WRONG AND WHAT SHOULD BE DONE ABOUT IT.

TEAR ALONG PERFORATED LINE

PRINTED NAME, GRADE OR TITLE AND TELEPHONE NUMBER

SIGN HERE

DA FORM 1 JUL 79 **2028-2**

PREVIOUS EDITIONS ARE OBSOLETE.

P.S.--IF YOUR OUTFIT WANTS TO KNOW ABOUT YOUR RECOMMENDATION MAKE A CARBON COPY OF THIS AND GIVE IT TO YOUR HEADQUARTERS.

PIN: 029316-000